

B.E.G.

LUXOMAT® net

KNX IP Router with KNX Security



LK-IP/KNXs REG

Operating Manual

90403

All device data can also be found here:



<https://beg-luxomat.com/qr.php?prtno=90403>

© 2020

B.E.G. Brück Electronic GmbH
Gerberstraße 33
51789 LindlarGERMANY

Phone: +49 (0) 2266 90121-0

Fax: +49 (0) 2266 90121-50

E-mail: info@beg.de

Internet: www.beg-luxomat.com

1	About this document	3
1.1	Other applicable documents	3
1.2	Used symbols and signal words	3
2	Safety	3
2.1	Intended use	3
2.2	Foreseeable misuse	4
2.3	Qualified persons / electricians	4
2.3.1	Certified electricians	4
2.4	Disclaimer	5
3	Device description	5
3.1	Device overview	5
3.2	Functions	6
3.2.1	KNX Security	6
3.2.2	KNX IP Security for the router function	6
3.2.3	KNX IP Security for the interface function	6
3.2.4	KNX Data Security for the device	7
3.2.5	KNX Data Security for group telegrams	7
3.2.6	Coupler function (KNXnet/IP Routing)	7
4	Mounting	11
5	Electrical connection	12
6	Commissioning	13
6.1	Factory default settings	13
6.1.1	Reset to factory default settings	13
6.2	KNX programming mode	13
6.3	Manual operation and status display	14
6.4	Commissioning via ETS	16
6.4.1	Programming with the ETS	16
6.4.1.1	Via the KNX bus	16
6.4.1.2	Via KNXnet/IP Tunneling	16
6.4.1.3	Via KNXnet/IP Routing	16
6.4.1.4	Via direct IP connection	16

6.4.2	Interface settings within ETS	17
6.4.3	ETS product database	19
6.4.4	Project password	20
6.4.5	Device certificate	21
6.4.6	Device properties	22
	KNX addresses	22
	Device properties – Settings	23
	Device properties – IP	25
6.4.7	Setting parameters with the ETS	27
	General settings	27
	Routing (KNX -> IP)	27
	Routing (IP -> KNX)	29
6.4.8	Filter table	31
7	Care, maintenance and disposal	32
7.1	Cleaning	32
7.2	Maintenance	32
7.3	Disposing	32
8	Diagnostics and troubleshooting	32
9	Service and support	33
9.1	Manufacturer's warranty	33
9.1.1	Product code	33
9.2	Contact details	33
10	Technical Data	34
10.1	General data	34
10.2	Dimensioned drawings LK-IP/KNXs REG	35
11	EU declaration of conformity	35
12	Annex – Open Source Licenses	36



1 About this document

1.1 Other applicable documents

Short operating manual

90403M1_Short_MAN_LK-IP_KNXs_REG_de_en_fr_nl_V1 (supplied with the device).

1.2 Used symbols and signal words



	Symbol indicating possible dangers to persons
	Symbol indicating possible property damage
	Symbol for useful information and tips
NOTICE	Signal word for possible property damage
CAUTION	Signal word for possible minor injuries
WARNING	Signal word for possible serious injuries
DANGER	Signal word for possible fatal injuries

2 Safety

The KNX IP Router LK-IP/KNXs REG was developed, manufactured and tested in accordance with the applicable safety standards. It corresponds to the state of the art.

2.1 Intended use

The device is a KNX IP router with KNX security for indoor installation in the sub-distribution cabinet.

 CAUTION	
	<p>Observe intended use!</p> <p>The protection of personnel and the device cannot be guaranteed if the device is operated in a manner not complying with its intended use.</p> <ul style="list-style-type: none"> → Only operate the device in accordance with its intended use. → B.E.G. Brück Electronic GmbH is not liable for damages caused by improper use. → Read these operating instructions before commissioning the device. Knowledge of the operating instructions is an element of proper use.

NOTICE

**Comply with conditions and regulations!**

→ Observe the locally applicable legal regulations and the rules of the employer's liability insurance association.

2.2 Foreseeable misuse

Any use other than that defined under "Intended use" or which goes beyond that use is considered improper use.

In particular, use of the device is not permitted in the following cases:

- in rooms with explosive atmospheres
- in circuits which are relevant to safety
- for medical purposes

NOTICE

**Do not modify or otherwise interfere with the device!**

→ Do not carry out modifications or otherwise interfere with the device. The device must not be tampered with and must not be changed in any way.

→ The device must not be opened. There are no user-serviceable parts inside.

→ Repairs must only be performed by B.E.G. Brück Electronic GmbH.

2.3 Qualified persons / electricians

Connection, mounting, commissioning and adjustment of the device must only be carried out by competent persons.

Prerequisites for competent persons:

- They have a suitable technical education.
- They are familiar with the rules and regulations for occupational safety and safety at work.
- They are familiar with the operating instructions for the device.
- They have been instructed by the responsible person on the mounting and operation of the device.

2.3.1 Certified electricians

Work on electrical equipment may only be carried out by certified electricians or by instructed persons under the direction and supervision of a certified electrician in accordance with the electrical engineering regulations.

Due to their technical training, knowledge and experience as well as their familiarity with relevant standards and regulations, certified electricians are able to perform work on electrical systems and independently detect possible dangers.

In Germany, certified electricians must fulfill the requirements of accident-prevention regulations DGUV (German Social Accident Insurance) provision 3 (e.g. electrician foreman). In other countries, there are respective regulations that must be observed.

2.4 Disclaimer

B.E.G. Brück Electronic GmbH is not liable in the following cases:

- The device is not being used properly.
- Reasonably foreseeable misuse is not taken into account.
- Mounting and electrical connection are not properly performed.
- Changes (e.g., constructional) are made to the device.

3 Device description

3.1 Device overview

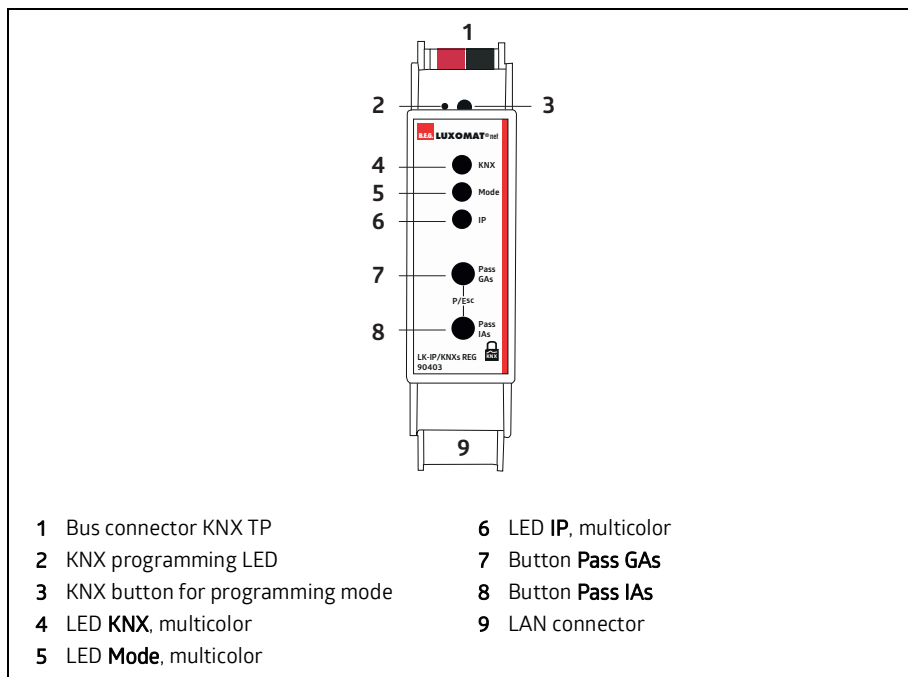

The compact KNX IP router LK-IP/KNXs REG enables the forwarding of telegrams between different lines via a LAN (IP) as a fast backbone. The device also serves as a programming interface between a PC and the KNX bus (e.g. for ETS programming).

The device supports KNX Security. The option can be activated in the ETS. As a secure router, the device enables the coupling of unsecured communication on a KNX TP line with a secure IP backbone.

KNX Security also prevents unauthorised access to the interface function (tunneling).

The IP address can be assigned via DHCP or via the ETS configuration. The device operates according to the KNXnet/IP specification using core, device management, tunneling and routing. The LK-IP/KNXs REG has an extended filter table for main groups 0 ... 31 and can buffer up to 150 telegrams. Power is supplied via the KNX bus.

3.2 Functions

3.2.1 KNX Security

The KNX standard was extended by **KNX Security** to protect KNX installations from unauthorized access. KNX Security reliably prevents the monitoring of communication as well as the manipulation of the system.

The specification for KNX Security distinguishes between **KNX IP Security** and **KNX Data Security**. KNX IP Security protects the communication over IP while on KNX TP the communication remains unencrypted. Thus KNX IP Security can also be used in existing KNX systems and with non-secure KNX TP devices.

KNX Data Security describes the encryption at telegram level. This means that the telegrams on the twisted pair bus are also encrypted.

3.2.2 KNX IP Security for the router function

The coupling of individual KNX TP lines via IP is referred as KNX IP routing. Communication between all connected KNX IP routers takes place via UDP multicast.

Routing communication is encrypted with KNX IP Security. This means that only IP devices that know the key can decrypt the communication and send valid telegrams. A time stamp in the routing telegram ensures that no previously recorded telegrams can be replayed. This prevents the so-called replay attack.

The key for the routing communication is reassigned by ETS for each installation. If KNX IP Security is used for routing, all connected KNX IP devices must support security and be configured accordingly.

3.2.3 KNX IP Security for the interface function

When using a KNX IP router as an interface to the bus, access to the installation is possible without security for all devices that have access to the IP network. With KNX Security a password is required. A secure connection is already established for the transfer of the password. All communication via IP is encrypted and secured.

3.2.4 KNX Data Security for the device

The LK-IP/KNXs REG also supports KNX Data Security to protect the device from unauthorised access from the KNX bus. If the KNX IP router is programmed via the KNX bus, this is done with encrypted telegrams.

INFO	
	<p>Encrypted telegrams!</p> <p>Encrypted telegrams are longer than the previously used unencrypted ones. For secure programming via the bus, it is therefore necessary that the interface used (e. g. USB) and any intermediate line couplers support the so-called KNX long frames.</p>

3.2.5 KNX Data Security for group telegrams

Telegrams from the bus that do not address the KNX IP router as a device are forwarded or blocked according to the filter settings (parameters and filter table). It does not matter whether the telegrams are unencrypted or encrypted. Forwarding takes place exclusively on the basis of the destination address. The security properties are checked by the respective recipient.

KNX Data Security and KNX IP Security can be used in parallel. In this case, for example, a KNX sensor would send a group telegram encrypted with KNX Data Security to the bus. When forwarding via KNX IP with KNX IP Security, the encrypted telegram would be encrypted again just like unencrypted ones. All participants on the KNX IP level that support KNX IP Security can decode the IP encryption, but not the data security.

Thus the telegram from the other KNX IP routers is again transmitted to the target line(s) with KNX Data Security. Only devices that know the key used for data security can interpret the telegram.

3.2.6 Coupler function (KNXnet/IP Routing)

The LK-IP/KNXs REG operates as a line or backbone coupler. In both cases, the LAN (IP) is used as a backbone.

The following table shows the application possibilities of the LK-IP/KNXs REG compared to the classic topology:

	Classical Topologie (without IP)	IP coupling of areas (IP area coupler)	IP coupling of lines (IP line coupler)
Area (Backbone)	TP	IP	IP
Coupling	KNX line coupler (max. 15 pcs.)	KNX IP router (max. 15 pcs)	direct via LAN switch
Main line	TP	TP	IP
Coupling	KNX line coupler (max. 15 x 15 = 225 pcs.)	KNX line coupler (max. 15 x 15 = 225 pcs.)	KNX-IP-router (max. 15 x 15 = 225 pcs.)
Line	TP	TP	TP

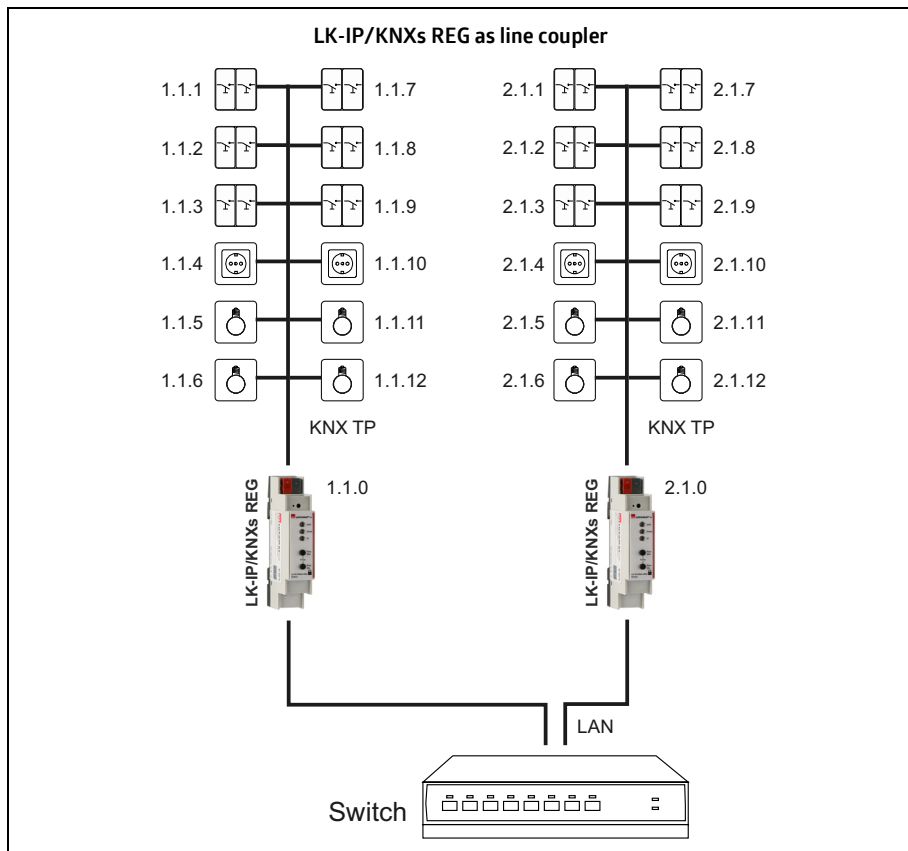

The individual address assigned to the LK-IP/KNXs REG determines whether the device operates as a line or area coupler.

- If the individual address is in the form of **x.y.0** (x, y: 1..15), the router operates as a line coupler.
- If it is in the form of **x.0.0** (x: 1..15), the router acts as a backbone coupler.

NOTICE

LK-IP/KNXs REG as line coupler!



If the LK-IP/KNXs REG is used as a line coupler (x.y.0), there must not be a KNX IP router in the topology above it.

For example, if a KNX IP Router has the individual address 1.1.0, there must be no KNX IP Router with the address 1.0.0.

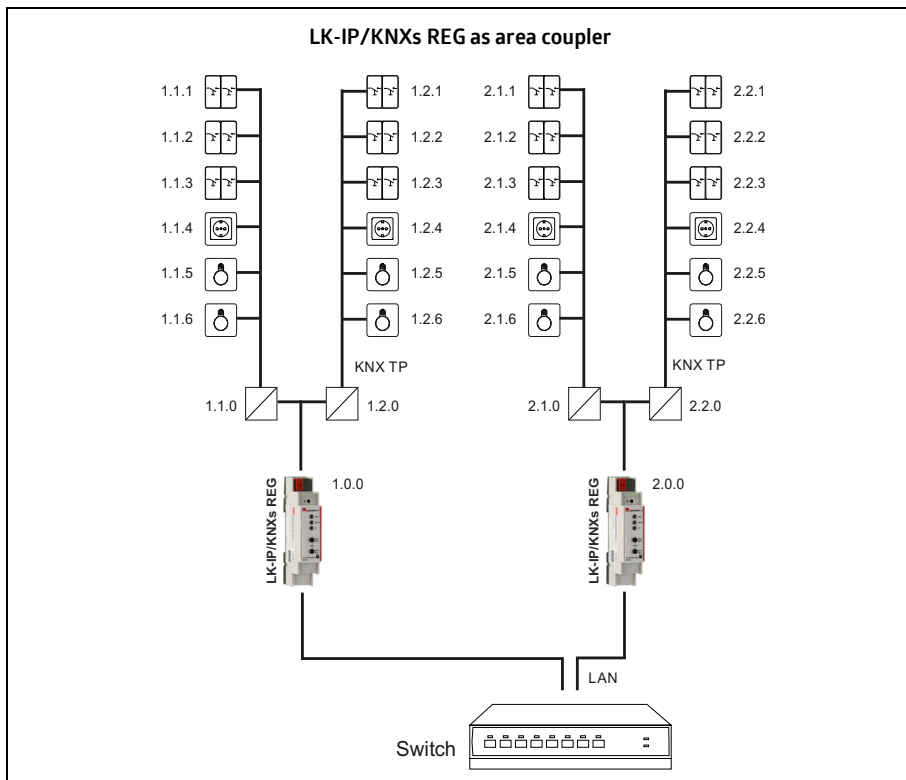

NOTICE

LK-IP/KNXs REG as area coupler!



If the LK-IP/KNXs REG is used as an area coupler (x.0.0), there must not be a KNX IP Router in the topology beneath it.

For example, if a KNX IP router has the individual address 1.0.0, there must be no KNX IP router with the address 1.1.0.

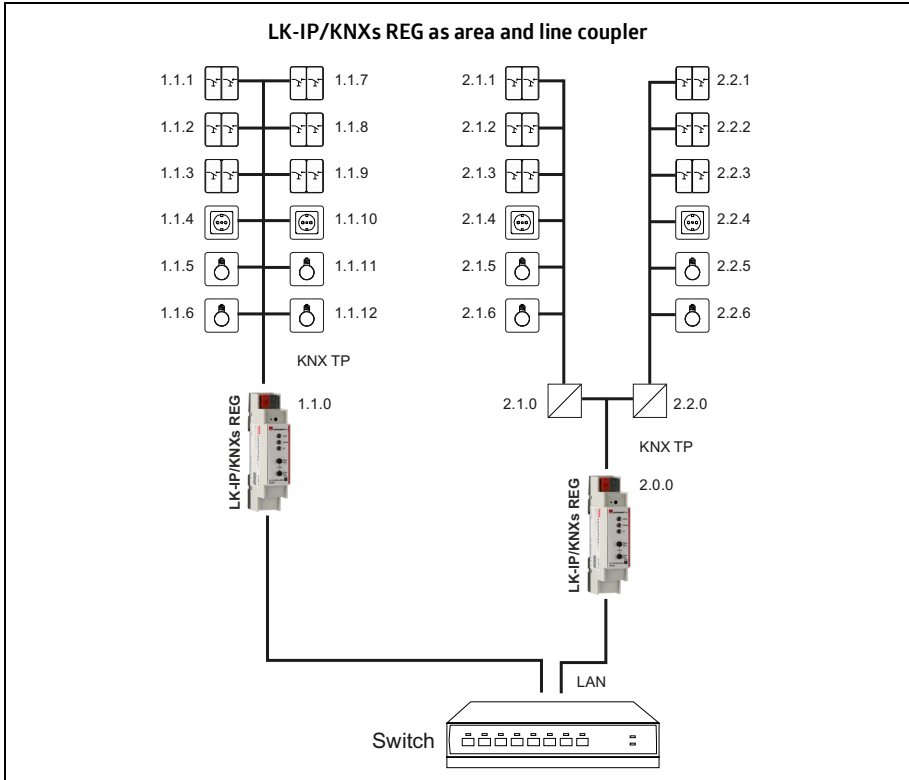

The KNX IP router has a filter table and thus contributes to reducing the bus load. The filter table (8 kB) supports the extended group address range (main groups 0 ... 31) and is automatically generated by the ETS.

Because of the speed difference between the Ethernet (10/100 MBit/s) and KNX TP (9.6 kBit/s), a far greater number of telegrams can be transmitted on IP. If several consecutive telegrams are transmitted for the same line, they must be buffered in the router to avoid telegram loss. The LK-IP/KNXs REG has a memory for 150 telegrams (from IP to KNX).

4 Mounting

The LK-IP/KNXs REG is fixed to a top-hat DIN rail in the sub-distributor and requires 1 division unit (18 mm) of space.

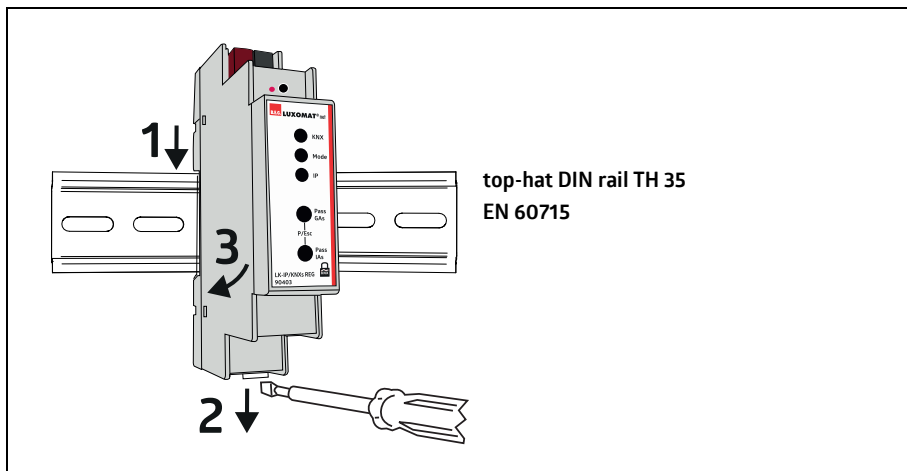

⚠ CAUTION



Observe KNX installation regulations!

This device complies with the KNX guidelines. Detailed knowledge of the KNX system is required for commissioning.

5 Electrical connection

⚠ CAUTION



Observe KNX installation regulations!

This device complies with the KNX guidelines. Detailed knowledge of the KNX system is required for commissioning.

The device is powered via the KNX bus main line connection. It is not necessary to connect an external supply voltage.

NOTICE



Missing bus voltage!

If there is no bus voltage (main line), the device has no function.

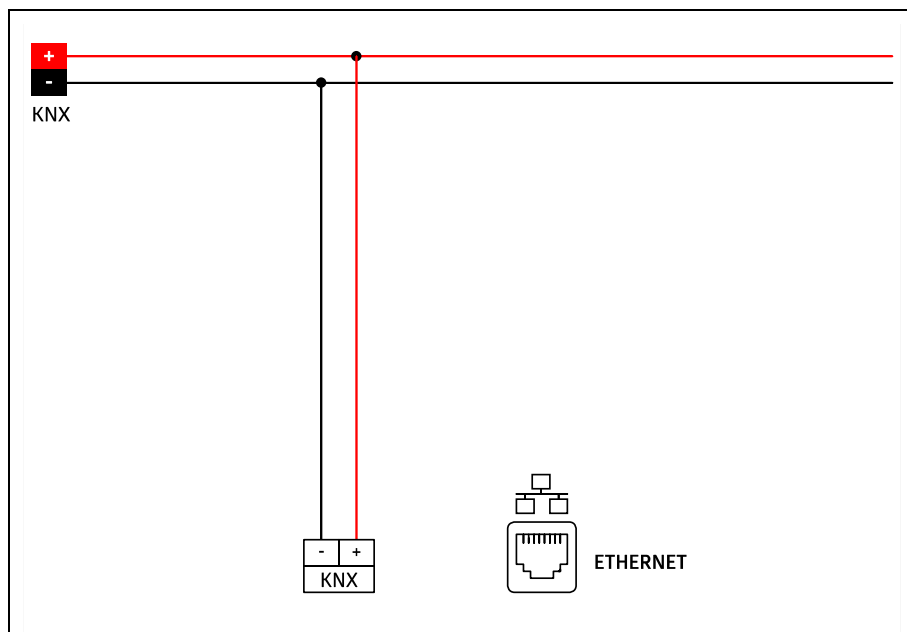

6 Commissioning

6.1 Factory default settings

The following configuration is set by factory default:

Individual device address:	15.15.0
Number of configured KNXnet/IP tunneling connections:	1
Individual address of tunneling connection:	15.15.240
IP address assignment:	DHCP
Initial key (FDSK):	active
Security mode:	not active

6.1.1 Reset to factory default settings

CAUTION



Factory default settings!

The individually made settings are lost.

It is possible to reset the device to its factory settings:

- Separate the KNX bus connector (1) from device
- Press the KNX programming button (3) and keep it pressed down
- Reconnect the KNX bus connector (1) to the device
- Keep the KNX programming button (3) pressed for at least another 6 seconds
- A short flashing of all LEDs (2, 4, 5, 6) visualizes the successful reset of the device to factory default settings.

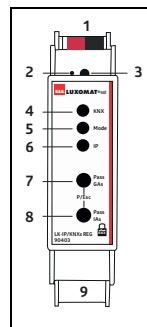

6.2 KNX programming mode

The KNX programming mode is activated/deactivated either by pressing the flushed KNX programming button (3) or by simultaneously pressing the buttons (7) and (8).

6.3 Manual operation and status display

The **KNX LED (4)** lights up green if the device is successfully powered by the KNX bus. If the LED is flickering, telegram traffic takes place on the KNX bus.

Errors in the communication (e.g. repetitions of telegrams or telegram fragments) are indicated by a short change of the LED color to red.

Overview of the different indications of the KNX LED (4):

LED Status	Meaning
LED lights green	KNX bus voltage available.
LED flickers green	Telegram traffic on the KNX bus.
LED flashes red shortly	Communication error on the KNX bus.

The **IP LED (6)** lights up when an Ethernet link is active. This LED is green if the device has valid IP settings (IP address, Sub net and Gateway). With invalid or nonexistent IP settings the LED is red. This is also the case if e.g. the device has not yet received the IP settings by a DHCP server. The LED indicates IP telegram traffic by flickering.

Overview of the different indications of the IP LED (6):

LED Status	Meaning
LED lights green	The device has an active Ethernet link and valid IP settings.
LED lights red	The device has an active Ethernet link and invalid IP settings or not yet received the IP settings by a DHCP server.
LED flickers green	IP telegram traffic.

For testing purposes (for example, during commissioning) the configured routing settings (**Filter** or **Block**) can be bypassed via manual operation.

With the button **Pass GAs (7)** the forwarding of group addressed telegrams can be activated.

With the button **Pass IAs (8)** the forwarding of individually addressed telegrams can be activated.

This is visualized with a single flash of the **Mode LED (5, orange)**. If both modes are activated the **Mode LED** flashes two times.

Pressing button **Pass GAs (7)** or **Pass IAs (8)** again these settings can be selected and deselected on demand. Via the Escape function (**Esc**) the manual operation can be stopped by simultaneously pressing the buttons **Pass GAs (7)** and **Pass IAs (8)**.

If neither programming mode nor manual mode are active the **Mode LED (5)** can visualize configuration errors (for details see following table).

Overview of the different indications of the Mode LED (5):

LED Status	Meaning
LED lights green	Device is working in standard operation mode.
LED lights red	Programming mode is active.
LED flashes 1 x orange	Programming mode is not active. Manual operation is active: Forwarding IA or GA
LED flashes 2 x orange	Programming mode is not active. Manual operation is active: Forwarding IA and GA
LED flashes red	Programming mode is not active. Manual operation is not active: The device is not properly loaded e.g. after an interrupted down-load.

6.4 Commissioning via ETS

6.4.1 Programming with the ETS

The LK-IP/KNXs REG can be programmed in different ways via the ETS:

6.4.1.1 Via the KNX bus

The device only needs to be connected to the KNX bus. The ETS requires an additional interface (for example, USB) to have access to the bus. Via this way both the individual address and the entire application including IP configuration can be programmed. Programming via the bus is recommended if no IP connection can be established.

6.4.1.2 Via KNXnet/IP Tunneling

No additional interface is required. Programming via KNXnet/IP Tunneling is possible if the device already has a valid IP configuration (e.g. via DHCP). In this case the device is displayed in the interface configuration of the ETS and must be selected. The download is executed via the ETS project as with many other devices.

6.4.1.3 Via KNXnet/IP Routing

Programming via KNXnet/IP Routing is possible if the device already has a valid IP configuration (e.g. by using DHCP or Auto IP). In the ETS, the routing interface appears if at least one device on the network which supports routing is available. The name of the network interface appears in the PC as description. If routing is selected as interface, the programming is done from the ETS project as like with other devices. In this case LAN is used as a KNX medium like TP. There is no additional interface device required.

6.4.1.4 Via direct IP connection

While KNXnet/IP Tunneling and KNXnet/IP Routing is limited to the speed of KNX TP the device can be loaded via a direct IP connection at high speed. The direct IP connection is possible if the device already has a valid IP configuration as well as a physical address. To do this, select "**Use direct IP connection if possible**" in the ETS menu under "**Bus -> Connections -> Options**". The download then takes place directly into the device and is not visible in the ETS group monitor.

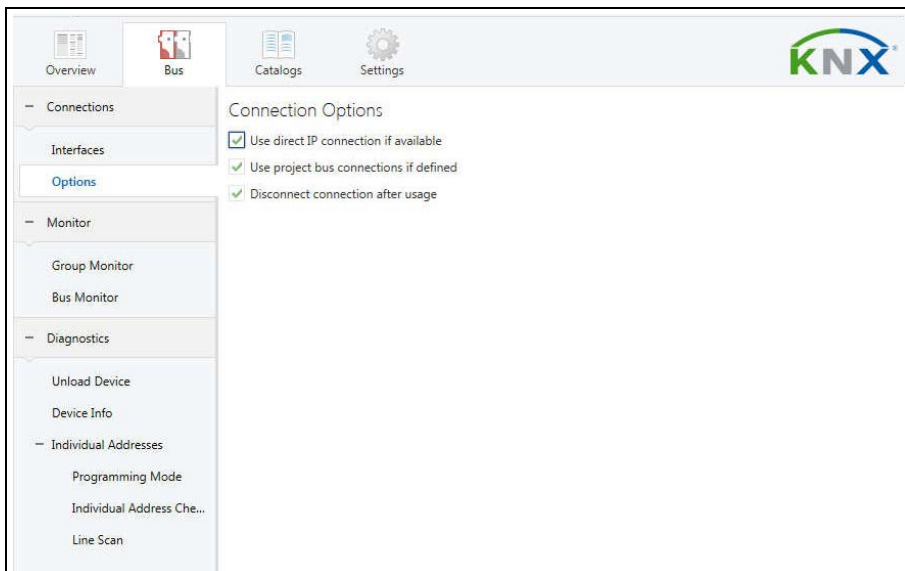

INFO



Due to the significantly shorter transmission times, it is recommended to perform downloads via IP.

6.4.2 Interface settings within ETS

Within the ETS, KNX interfaces can be selected and set up via the ETS menu **"Bus -> Interfaces"**.

The ETS can access configured KNX IP routers even without a database entry. If the setup of the KNX IP router does not comply with the conditions of the KNX installation it must be configured via an ETS project. See section "ETS product database" on page 19 for more information.

As factory default the assignment of the IP address is set to "automatically via DHCP" and thus no further settings are necessary. To use this feature a DHCP server on the LAN must exist (e.g. many DSL routers have an integrated DHCP server).

After connecting the KNX IP router to the LAN and the KNX bus, it should automatically appear in the ETS within the menu **"Bus"** under **"Discovered interfaces"**.

By clicking on the discovered interface it is selected as the current interface. On the right side of the ETS window all specific information and options of the connection appear.

The indicated device name and the **"Host Individual Address"** (individual address of the device) can be changed within your ETS project then.

B.E.G. LUXOMAT[®] net LK-IP/KNXs REG 90403

Like all programmable KNX devices the LK-IP/KNXs REG has an individual address which can be used to access the device. This is used, for example, of the ETS when downloading to the KNX IP router via the bus.

For the interface function the device contains additional individual addresses that can be set in the ETS. When a client (e.g. ETS) sends telegrams to the bus via the KNX IP router, these contain one of the additional addresses as the sender address. Each address is assigned to a connection. This means that response telegrams can be uniquely forwarded to the respective client.

The additional individual addresses must be selected from the address range of the bus line in which the router is installed and may not be used by another device.

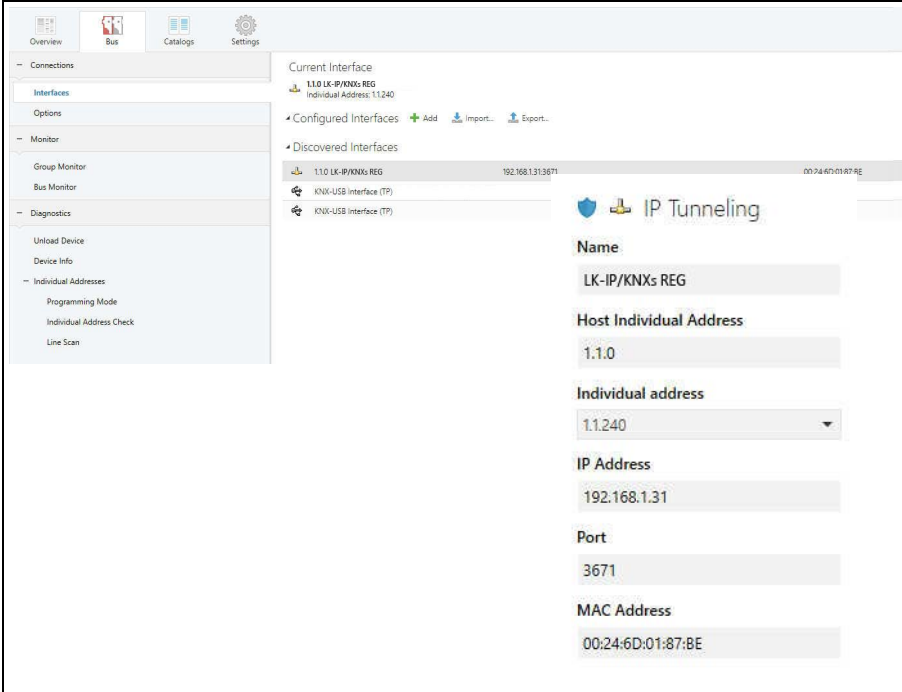

The screenshot displays the ETS software interface for configuring the LK-IP/KNXs REG device. The interface is divided into a sidebar on the left and a main content area on the right. The sidebar contains navigation options: Overview, Bus, Catalogs, and Settings. The main content area is titled 'Current Interface' and shows the configuration for the selected device, '1.1.0 LK-IP/KNXs REG', with an individual address of 1.1.240. Below this, there are sections for 'Configured Interfaces' and 'Discovered Interfaces'. The 'Discovered Interfaces' section lists the device with its IP address (192.168.1.31) and port (3671). The right-hand side of the interface shows the 'IP Tunneling' configuration for the selected interface, with fields for Name, Host Individual Address (1.1.0), Individual address (1.1.240), IP Address (192.168.1.31), Port (3671), and MAC Address (00:24:6D:01:87:BE).

The individual KNX device address and the individual addresses for additional tunneling connections can be changed within the ETS project after the device has been added to the project.

6.4.3 ETS product database

The ETS product database (ETS 5.7 or higher) can be downloaded from the product website of the LK-IP/KNXs REG:



<https://beg-luxomat.com/qr.php?prtno=90403>

6.4.4 Project password

If the first product is inserted into a project with KNX Security, the ETS prompts you to enter a project password.

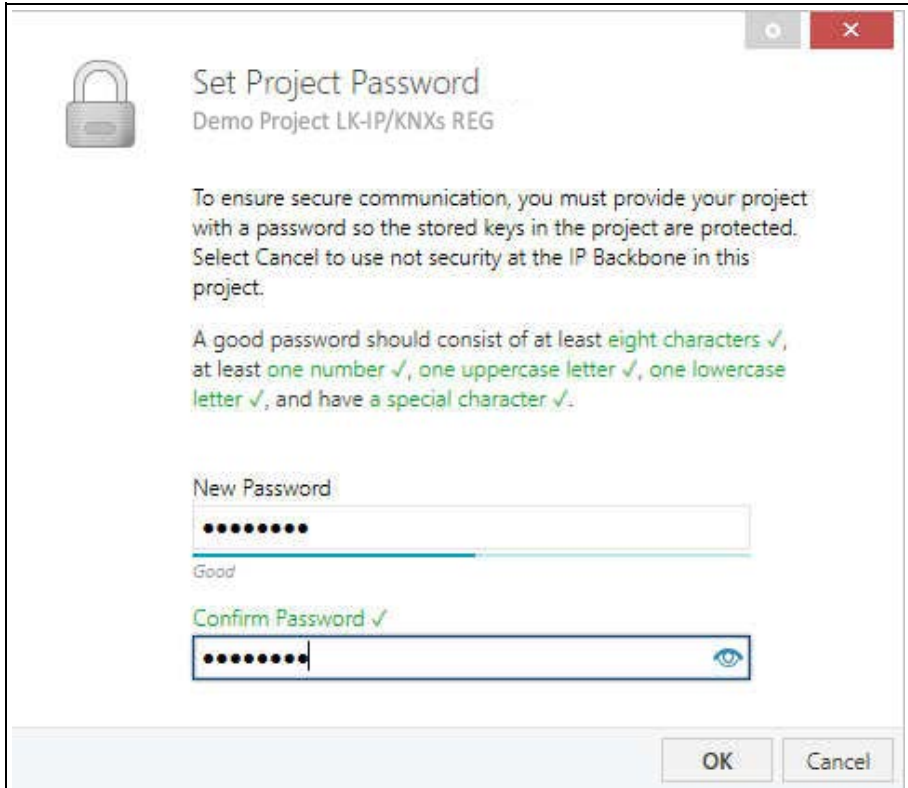

This password protects the ETS project against unauthorized access. This password is not a key that is used for KNX communication. The entry of the password can be bypassed with "Cancel", but this is not recommended for security reasons.

6.4.5 Device certificate

ETS requires a device certificate for each device with KNX Security that is created in the ETS. This certificate contains the serial number of the device as well as an intangible key (**FDSK** = Factory Default Setup Key).

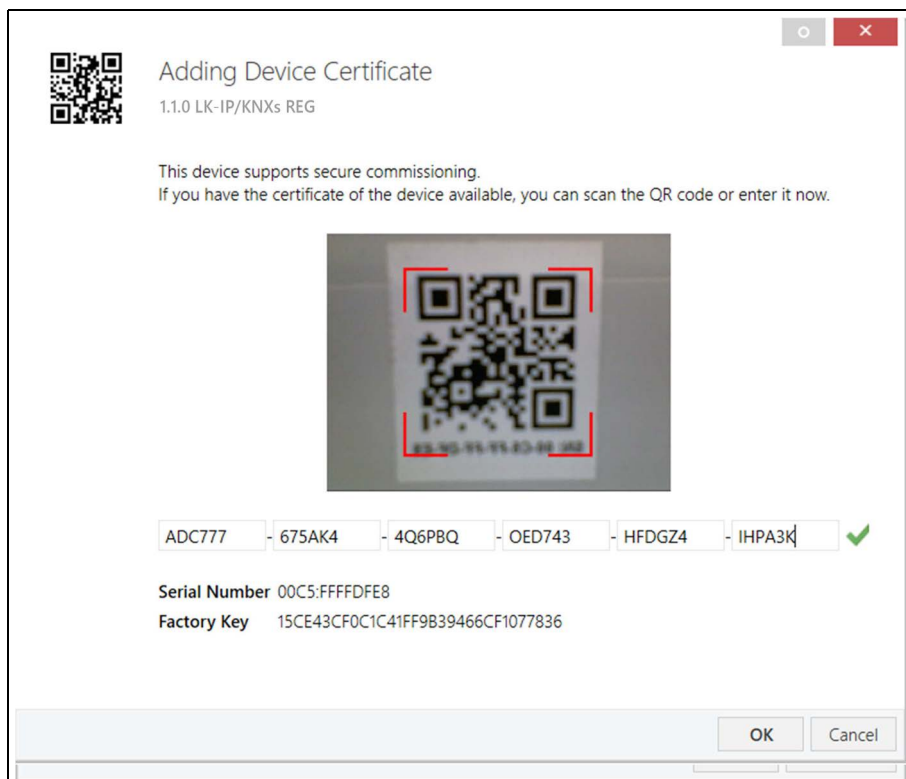

The certificate is printed as text on the device. It can also be conveniently scanned from the printed QR code via a webcam.

The list of all device certificates can be managed in the ETS **Overview** -> **Projects** -> **Security** window.

This initial key is required to safely put a device into operation from the start. Even if the ETS download is recorded by a third party, the third party has no access to the secured devices afterwards. During the first secure download, the initial key is replaced by the ETS with a new key that is generated individually for each device. This prevents persons or devices who may know the initial key from accessing the device. The initial key is only reactivated after a master reset.

The serial number in the certificate enables the ETS to assign the correct key to a device during a download.

6.4.6 Device properties

In the ETS, some settings are displayed in addition to the parameter dialog in the properties dialog (at the edge of the screen). The IP settings can be made here.

KNX addresses

The additional addresses for the interface connections are displayed in the topology view.

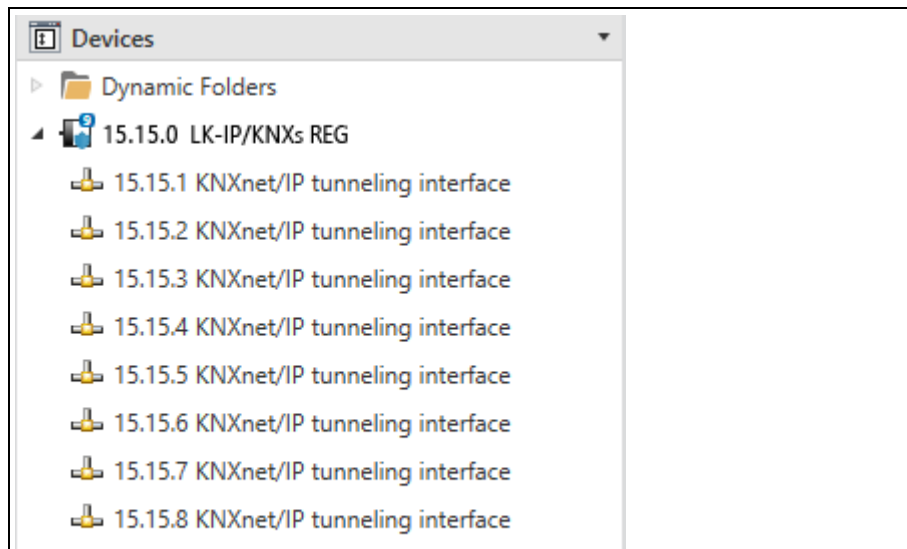

Each individual KNX address can be changed by clicking on the list entry and typing in the desired address into the "Individual Address" text-field. If the text-field frame switches to color red after entering the address, the address is already taken within your ETS project.

NOTICE



Addressing!

Make sure that none of the addresses above is already in use within your KNX installation.

Device properties – Settings

By clicking on the LK-IP/KNXs REG device entry within your ETS projects topology view, an information column "Properties" will appear on the right side of the ETS window. Within the "Settings" overview, you can change the device name of the LK-IP/KNXs REG.

Properties

Settings IP Comments Information

Name
LK-IP/KNXs REG

Individual Address
1.1 . 0 Park

Description

Last Modified 07.05.2019 12:29
Last Downloaded 07.05.2019 12:29
Serial Number 00C5:01021BA7

Secure Commissioning
Activated

Add Device Certificate

Secure Tunneling
Activated

Status
Unknown

If secure tunneling is activated, a unique password will be created automatically for each tunnel. This password can be displayed under the "Settings" overview, when a tunnel is selected.

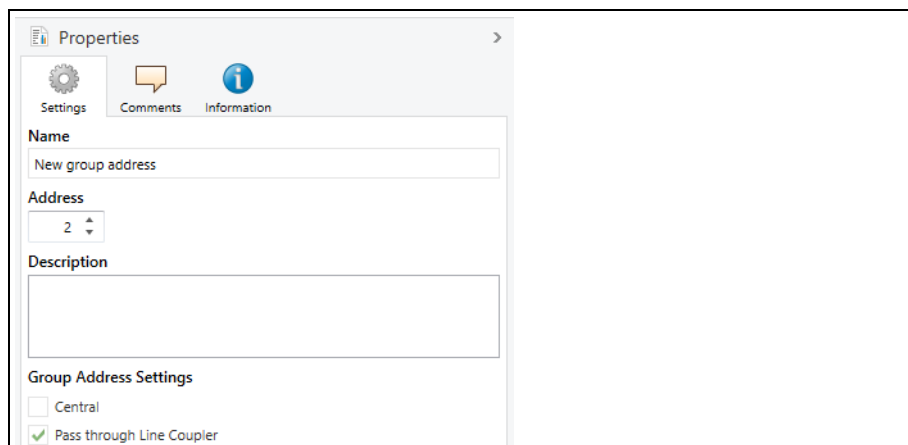

The screenshot shows a 'Properties' dialog box with a title bar and a right-pointing arrow. Below the title bar are three tabs: 'Settings' (with a gear icon), 'Comments' (with a speech bubble icon), and 'Information' (with an 'i' icon). The 'Settings' tab is active. The dialog contains the following fields and options:

- Name:** A text input field containing 'New group address'.
- Address:** A dropdown menu showing the value '2'.
- Description:** A large, empty text area.
- Group Address Settings:** A section containing two checkboxes:
 - Central
 - Pass through Line Coupler

Device properties – IP

Within the “IP” overview the IP network specific options of the LK-IP/KNXs REG can be changed.

By changing “Obtain an IP address automatically” (via DHCP) to “Use a static IP address” (fixed IP address) the IP address, subnet mask, and default gateway can be set freely.

The screenshot displays the 'IP' configuration page. At the top, there are four tabs: 'Settings', 'IP', 'Comments', and 'Information'. The 'IP' tab is selected. Below the tabs, there are two radio button options: 'Obtain an IP address automatically' (unselected) and 'Use a static IP address' (selected). Below these are several input fields with their current values: 'IP Address' (192.168.1.31), 'Subnet Mask' (255.255.255.0), 'Default Gateway' (192.168.1.1), 'MAC Address' (00:24:6D:01:87:BE), 'Multicast Address' (224.0.23.12), 'Commissioning Password' (Nu_78:+k), and 'Authentication Code' (*Ah<Ptm{). Each field has a green progress bar below it, and the word 'Good' is displayed at the bottom of the page.

NOTICE



All changes in the properties menu become effective only after a successful application download.

IP address

Here the IP address of the LK-IP/KNXs REG can be entered. This is used to address the device via the IP network (LAN). The IP addressing should be coordinated with the administrator of the network.

Subnet mask

Enter the subnet mask here. The device uses the values entered in this mask to determine whether there is a communication partner in the local network. If there is no partner in the local network, the device will not send the telegrams directly to the partner but to the gateway that routes the telegram.

Default gateway

Enter the IP address of the gateway here, e.g. the DSL router of the installation.

Routing Multicast Address

This address is used for routing telegrams on IP. The multicast IP address **224.0.23.12** was reserved at the IANA (Internet Assigned Numbers Authority) for this purpose (KNXnet/IP). If a different multicast IP address is required, it must be within the range of **239.0.0.0 to 239.255.255.255**.

Example for the assignment of IP addresses:

A PC is used to access the LK-IP/KNXs REG.

IP address of the PC: 192.168.1.30

Subnet of the PC: 255.255.255.0

The LK-IP/KNXs REG is located in the same local LAN, i.e. it uses the same subnet. The subnet constrains the IP addresses that can be assigned. In this example, the IP address of the IP router must be 192.168.1.xx, where xx can be a number from 1 to 254 (with the exception of 30, which is already in use). It must be ensured that no numbers are assigned twice.

IP address of the KNX IP router: 192.168.1.31

Subnet of the KNX IP router: 255.255.255.0

6.4.7 Setting parameters with the ETS

The following parameters can be set using the ETS.

General settings

15.15.0 LK-IP/KNXs REG > General settings	
Description	Note: For device name and IP settings see dialog "Properties"
General settings	Prog. mode on device front <input type="radio"/> Disabled <input checked="" type="radio"/> Enabled
Routing (KNX -> IP)	Manual operation on device: Enabled without time limit
Routing (IP -> KNX)	

Prog. mode on device front

In addition to the normal programming button (3) the device allows activating the programming mode on the device front without opening the switchboard cover. The programming mode can be activated and deactivated via pressing simultaneously both buttons (7) and (8).

This feature can be enabled and disabled via the parameter "Prog. mode on device front". The recessed programming button (3) next to the programming LED (2) is always enabled and not influenced by this parameter.

Manual operation on device

This parameter sets the duration of the manual mode. Upon completion the normal display mode is restored.

Routing (KNX -> IP)

15.15.0 LK-IP/KNXs REG > Routing (KNX -> IP)	
Description	Group telegrams (main groups 0 to 13) Filter
General settings	Group telegrams (main groups 14 to 31) Filter
Routing (KNX -> IP)	Individual addressed telegrams Filter
Routing (IP -> KNX)	Broadcast telegrams <input type="radio"/> Block <input checked="" type="radio"/> Route
	Acknowledge (ACK) of group telegrams <input type="radio"/> Always <input checked="" type="radio"/> Only if routed
	Acknowledge (ACK) of individual addressed telegrams Only if routed

Group telegrams (main groups 0 to 13)

Disabling	No group telegram of these main groups is routed to IP.
Route	All group telegrams of these main groups are routed to IP independent of the filter table. This setting is for test purposes only.
Filter	The filter table is used to check whether or not the received group telegram should be routed to IP.

Group telegrams (main groups 14 to 31)

Disabling	No group telegram of main groups 14 to 31 is routed to IP.
Route	All group telegrams of main groups 14 to 31 are routed to IP.
Filter	The filter table is used to check whether or not the received group telegram should be routed to IP.

Individually addressed telegrams

Disabling	No individually addressed telegram is routed to IP.
Route	All individually addressed telegrams are routed to IP.
Filter	The individual address is used to check whether the received individually addressed telegram should be routed to IP.

Broadcast telegrams

Disabling	No received broadcast telegram is routed to IP.
Route	All received broadcast telegrams are routed to IP.

Acknowledge (ACK) of group telegrams

Always	An acknowledge is generated for every received group telegram (from KNX).
Only if routed	An acknowledge is only generated for received group telegrams (from KNX) if they are routed to IP.

Acknowledge (ACK) of individually addressed telegrams

Always	An acknowledge is generated for every received individual addressed telegram (from KNX).
Only if routed	An acknowledge is only generated for received individually addressed group telegrams (from KNX) if they are routed to IP.
Answer with NACK	Every received individually addressed telegram (from KNX) is responded to with NACK (Not acknowledge). This means that communication with individually addressed telegrams on the corresponding KNX line is not possible. Group communication (group telegrams) is not affected. This setting can be used to prevent manipulation attempts.

NOTICE

Answer with NACK!
 When using "Answer with NACK" an access to the device via KNX TP is no longer possible. The configuration must be performed via IP.

Routing (IP -> KNX)

Group telegrams (main groups 0 to 13)

- Disabling** No group telegram of these main groups is routed to KNX.
- Route** All group telegrams of these main groups are routed to KNX independent of the filter table. This setting is for test purposes only.
- Filter** The filter table is used to check whether or not the received group telegram should be routed to KNX.

Group telegrams (main groups 14 to 31)

- Disabling** No group telegram of main groups 14 to 31 is routed to KNX.
- Route** All group telegrams of main groups 14 to 31 are routed to KNX.
- Filter** The filter table is used to check whether or not the received group telegram should be routed to KNX.



Individually addressed telegrams

- Disabling** No individually addressed telegram is routed to KNX.
- Route** All individually addressed telegrams are routed to KNX.
- Filter** The individual address is used to check whether the received individually addressed telegram should be routed to KNX.

Broadcast telegrams

- Disabling** No received broadcast telegram is routed to KNX.
- Route** All received broadcast telegrams are routed to KNX.

Repetition of group telegrams

- Disabled** The received group telegram is not resent to KNX in case of a fault.
- Enabled** The received group telegram is resent up to three times in case of a fault.

Repetition of individually addressed telegrams

- Disabled** The received individually addressed telegram is not resent to KNX in case of a fault.
- Enabled** The received individually addressed telegram is resent up to three times in case of a fault.

Repetition of broadcast telegrams

- Disabled** The received broadcast telegram is not resent to KNX in case of a fault.
- Enabled** The received broadcast telegram is resent up to three times in case of a fault.

6.4.8 Filter table

The filter table is automatically created by the ETS. The group addresses of the telegrams which shall be forwarded via the router are added to the filter table. The content of the filter table can be displayed via the preview:

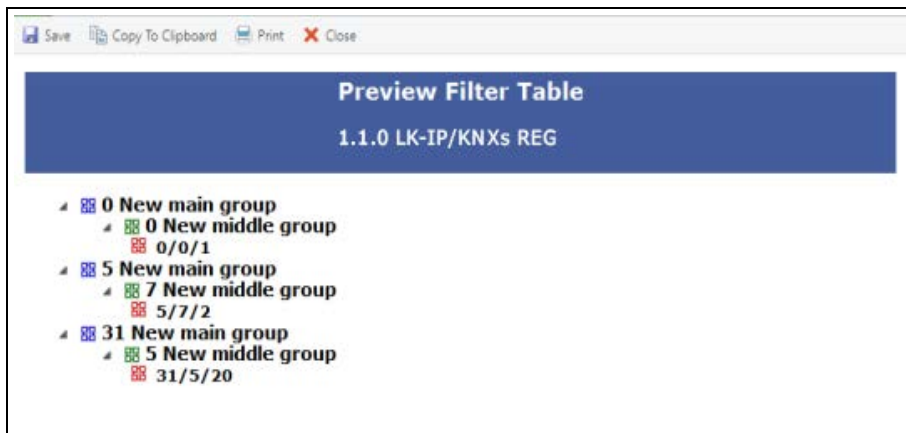

The filter table can be extended by manually adding group addresses.

This requires activating "**Pass through Router**" in the property window of the corresponding group address.

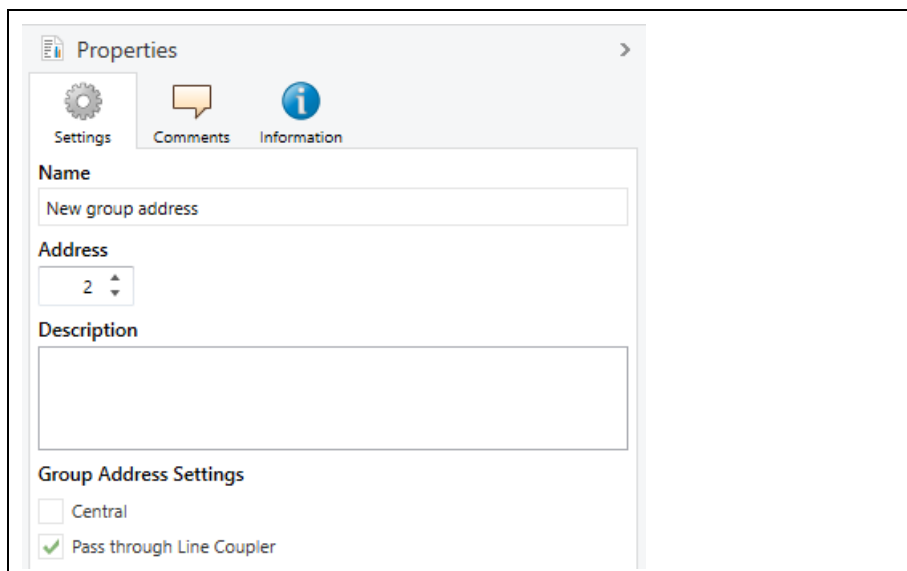

7 Care, maintenance and disposal

7.1 Cleaning

If necessary, clean the device surface with a soft, lint-free cloth.

NOTICE

Do not use aggressive cleaning agents!



→ Do not use aggressive cleaning agents such as thinner or acetone for cleaning the device.

→ To clean the device, use only a lint-free cloth.

Tips and hard objects can destroy the device.

7.2 Maintenance

Usually, the device does not require any maintenance by the operator. Repairs to the device must only be carried out by the manufacturer.

For repairs, contact your local B.E.G. Brück Electronic subsidiary or directly B.E.G. Brück Electronic GmbH, Germany.

7.3 Disposing

For disposal observe the applicable national regulations regarding electronic components.

8 Diagnostics and troubleshooting

NOTICE

Diagnosis / Troubleshooting via the ETS!



→ Use the corresponding ETS functions for diagnosis / troubleshooting, e.g.

- Group Monitor
- Bus Monitor
- Line Scan

9 Service and support

9.1 Manufacturer's warranty

The company B.E.G. Brück Electronic GmbH grants a warranty in accordance with the warranty conditions, which you can download from the website at <https://www.beg-luxomat.com/service/downloads/>.

9.1.1 Product code

The product is provided with a product code that enables the product to be traced in the event of a warranty/complaint.

The product code of the LK-IP/KNXs REG is labelled on the back of the housing.

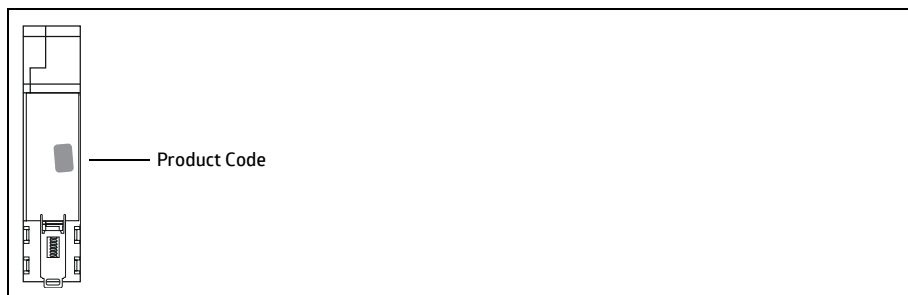

9.2 Contact details

Service hotline:

+49 (0)2266 90121-0

Monday to Thursday 8.00 to 16.00 (UTC+1)

Friday 8.00 to 15.00 (UTC+1)

E-mail:

support@beg.de

Return address for repairs:

Contact your B.E.G. subsidiary or representative.

The contact details can be found at <https://www.beg-luxomat.com/en-in/service/service-points/>.

Or contact us directly at

B.E.G. Brück Electronic GmbH

Gerberstrasse 33

51789 Lindlar

GERMANY

10 Technical Data

10.1 General data

Voltage	via KNX Bus
Current consumption	approx. 20 mA
Connections	RJ45-socket for LAN (Ethernet), bus connector red/black for KNX-TP
Ethernet	100BaseT (100MBit/s), internet protocols: ARP, ICMP, IGMP, UDP/IP, TCP/IP, DHCP and Auto IP
KNX	Device model: 0x091A Medium: IP/TP KNX Security (AES-128) incl. Tunneling V2, Core V2 Up to 8 KNXnet/IP Tunneling connections simultaneously Extended filter table for main group 0 ... 31 Max. APDU length: 55
Controls and indicators	2 buttons, 3 multicolor LEDs, KNX programming button with LED (red)
Housing	DIN rail-mounted device, polycarbonate
Housing width	18 mm (1 rail units)
Weight	approx. 40 g
Protection class / degree of protection	III / IP20
Ambient temperature (operating/storage)	-5 °C – +45 °C / -25 °C – +70 °C
Rel. humidity	5 – 93 % non-condensing
Conformity with standards	Low-voltage directive 2014/35/EU EMC Directive 2014/30/EU RoHS Directive 2011/65/EU EN 63044-3: 2018 EN 50491-5-1, -5-2, -5-3: 2010 EN 61000-6-2: 2005, EN 61000-6-3: 2007 + A1: 2011 EN 63000: 2018
Nameplate	<p>B.E.G. LUXOMAT® net KNX LK-IP/KNXs REG 90403</p> <p>SN: MAC: Cert:</p> <p>TP S X IP20 CE</p>

10.2 Dimensioned drawings LK-IP/KNXs REG

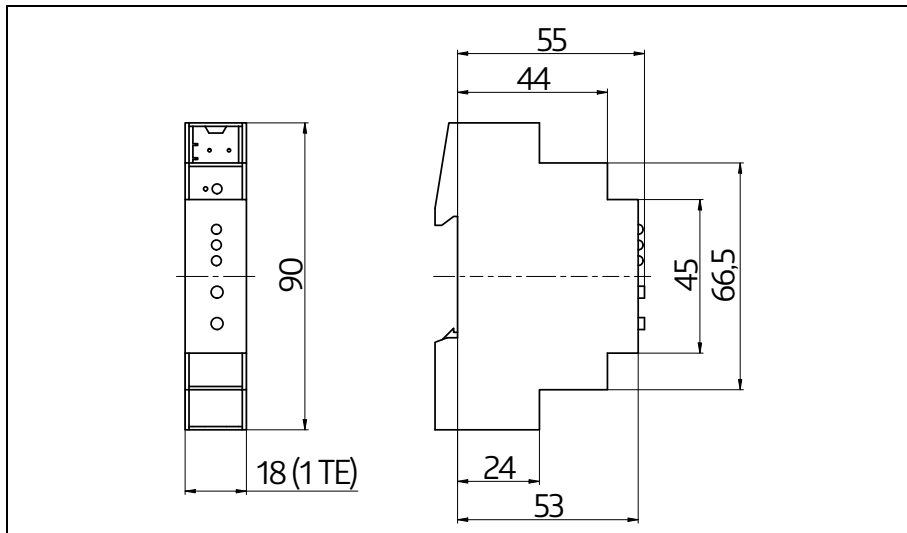

11 EU declaration of conformity

The product complies with the following EU directives

1. Electromagnetic Compatibility (2014/30/EU)
2. Low voltage (2014/35/EU)
3. Restriction of the use of certain hazardous substances in electrical and electronic equipment (2011/65/EU)

NOTICE



EU declaration of conformity

A detailed EU declaration of Conformity can be found at www.beg-luxomat.com or can be requested from the manufacturer.

12 Annex – Open Source Licenses

This product contains open source software license:

curve25519-donna: Curve25519 elliptic curve, public key function

Source: <http://code.google.com/p/curve25519-donna/>

Copyright 2008, Google Inc. All rights reserved.

Redistribution and use in source and binary forms, with or without modification, are permitted provided that the following conditions are met:

Redistributions of source code must retain the above copyright notice, this list of conditions and the following disclaimer. Redistributions in binary form must reproduce the above copyright notice, this list of conditions and the following disclaimer in the documentation and/or other materials provided with the distribution.

Neither the name of Google Inc. nor the names of its contributors may be used to endorse or promote products derived from this software without specific prior written permission.

THIS SOFTWARE IS PROVIDED BY THE COPYRIGHT HOLDERS AND CONTRIBUTORS "AS IS" AND ANY EXPRESS OR IMPLIED WARRANTIES, INCLUDING, BUT NOT LIMITED TO, THE IMPLIED WARRANTIES OF MERCHANTABILITY AND FITNESS FOR A PARTICULAR PURPOSE ARE DISCLAIMED. IN NO EVENT SHALL THE COPYRIGHT OWNER OR CONTRIBUTORS BE LIABLE FOR ANY DIRECT, INDIRECT, INCIDENTAL, SPECIAL, EXEMPLARY, OR CONSEQUENTIAL DAMAGES (INCLUDING, BUT NOT LIMITED TO, PROCUREMENT OF SUBSTITUTE GOODS OR SERVICES; LOSS OF USE, DATA, OR PROFITS; OR BUSINESS INTERRUPTION) HOWEVER CAUSED AND ON ANY THEORY OF LIABILITY, WHETHER IN CONTRACT, STRICT LIABILITY, OR TORT (INCLUDING NEGLIGENCE OR OTHERWISE) ARISING IN ANY WAY OUT OF THE USE OF THIS SOFTWARE, EVEN IF ADVISED OF THE POSSIBILITY OF SUCH DAMAGE.



Brück Electronic GmbH
Gerberstraße 33
51789 Lindlar
GERMANY

T +49 (0)2266-90121-0
F +49 (0)2266-90121-50

info@beg.de
beg-luxomat.com