

Universal dimming actuator and switching actuator



UAD1-230/KNXs REG

Application description

All device data can also be found here:



<https://beg-luxomat.com/qr.php?prtno=90225>

© 2025

B.E.G. Brück Electronic GmbH
Gerberstraße 33
51789 Lindlar
GERMANY

Phone: +49 (0) 2266 90121-0

E-Mail: support@beg.de

Internet: beg-luxomat.com

1	About this document	5
1.1	Applicable documents	5
1.2	Means of presentation used	5
1.3	Prerequisites for understanding	5
2	Security	6
2.1	Intended use	6
2.2	Foreseeable misuse	6
2.3	Qualified persons / qualified electricians	7
2.4	Disclaimer	7
3	General information	8
3.1	Basics of the KNX BUS	8
3.2	Symbolism	8
4	Functional description	9
4.1	Application	9
4.2	Device structure	10
5	Commissioning	11
5.1	Carry out ETS commissioning	11
5.2	KNX programming mode	12
5.3	Manual operation and status display	12
6	Reset to factory settings	13
7	Connection diagram	14
7.1	Pluggable screw terminals	14
7.2	Pin assignment	14
7.3	Operating parameters of the dimmer channel	15
8	KNX Security	17
9	ETS database	18
9.1	Secure commissioning	18
9.2	Secure group communication	18
10	General settings	19
10.1	Device name (30 characters)	19
10.2	Send delay after bus power return	19
10.3	Prog. mode on device front	19
10.4	Manual operation on device	19
10.5	Heartbeat	20
10.6	Operating mode	20





10.7	Long button press after	20
10.8	Logic / Timer	20
11	Operating mode dimmer	21
11.1	Diagnostics	21
11.2	Dimmer A: General	21
11.3	Dimmer A: Dimmer	23
11.4	Dimmer A: Staircase function	26
11.5	Dimmer A: Dimming curve	28
11.6	Dimmer A: Scene function	30
11.7	Dimmer A: Slumber function	31
11.8	Dimmer A: Lock function	32
11.9	Dimmer A: Sequencer	33
12	Operating mode switching actuator	36
12.1	Diagnostics	36
12.2	Actuator A: General	36
12.3	Actuator A: Lock function	38
12.4	Actuator A: Scene function	39
12.5	Actuator A: On/Off delay	39
12.6	Actuator A: Staircase function	40
12.7	Actuator A: Valve actuator	41
12.8	Actuator A: Lock function	42
13	Binary inputs	43
13.1	Input B1/B2: General	43
13.2	Input B1/B2: Switching	44
13.3	Input B1/B2: Dimming	45
13.4	Input B1/B2: Shutter	46
13.5	Input B1/B2: Send value	50
13.6	Input B1/B2: Scene	51
13.7	Input B1/B2: Generic	52
13.8	Input B1/B2: Scaled counter	54
13.9	Input B1/B2: Rate of change	56
13.10	Input B1/B2: Lock function	58
14	Logic / Timing	59
14.1	Function 1 - 16: Timer	59
14.2	Function 1 - 16: Logic	60
15	Service / Support	62
15.1	Manufacturer's warranty	62
15.2	Contact details	62

1 About this document

1.1 Applicable documents

Brief operating instructions (enclosed with the device).

1.2 Means of presentation used

	Symbol for danger to life due to electric shock
	Symbol for possible danger to persons
	Symbol for possible material damage
	Symbol for useful information and tips
HINT	Signal word for possible material damage
CAUTION	Signal word for possible minor injuries
WARNING	Signal word for possible serious injuries
DANGER	Signal word for possible fatal injuries

1.3 Prerequisites for understanding

HINT	
	<p>KNX knowledge A KNX commissioning or project planning course (at least ETS 5) is required to understand this application description.</p>

2 Security

The UAD1-230/KNXs REG has been developed, manufactured and tested in accordance with the applicable safety standards. It corresponds to the state of the art.

2.1 Intended use

The device is a compact 230 V dimmer with 1 dimmable output and 2 binary inputs. It is mounted on a top-hat rail in accordance with EN 60715 in the sub-distribution board indoors.

CAUTION	
	<p>Observe the intended use! The protection of operating personnel and the appliance is not guaranteed if the appliance is not used in accordance with its intended use.</p> <ul style="list-style-type: none"> → Only use the device in accordance with its intended use. → B.E.G. Brück Electronic GmbH is not liable for damage caused by improper use. → Read these operating instructions before commissioning the appliance. Knowledge of the operating instructions is part of the intended use.

HINT	
	<p>Comply with regulations and provisions! → Observe the locally applicable legal regulations and the regulations of the employers' liability insurance associations.</p>

WARNING	
	<p>Work on electrical systems may only be carried out by qualified electricians or by instructed persons under the direction and supervision of a qualified electrician in accordance with the electrotechnical regulations.</p> <p>Danger of electric shock. Device is not suitable for unlocking.</p> <p>Danger of electric shock. → Before working on the appliance or replacing lamps, disconnect the mains voltage and switch off the circuit breaker.</p>

2.2 Foreseeable misuse

Any use other than that specified under "Intended use" or any use beyond this is considered improper use.

Use of the device is not permitted in the following cases in particular:

- in rooms with explosive atmospheres
- in safety-relevant circuits
- for medical purposes

HINT	
	<p>Do not tamper with or modify the device! → Do not tamper with or modify the appliance. Interventions and modifications to the device are not permitted. → The appliance must not be opened. It does not contain any parts to be adjusted or maintained by the user. → Repairs may only be carried out by B.E.G. Brück Electronic GmbH.</p>

2.3 Qualified persons / qualified electricians

Connection, installation, commissioning and adjustment of the appliance may only be carried out by authorised persons.

Requirements for authorised persons:

- You have suitable technical training.
- They know the rules and regulations on occupational health and safety.
- You are familiar with the operating instructions for the device.
- They were instructed in the installation and operation of the appliance by the person responsible.

Qualified electricians

Work on electrical systems may only be carried out by qualified electricians or by instructed persons under the direction and supervision of a qualified electrician in accordance with the electrotechnical regulations.

Due to their specialist training, knowledge and experience as well as knowledge of the relevant standards and regulations, qualified electricians are able to carry out work on electrical systems and recognise potential hazards independently.

In Germany, qualified electricians must fulfil the provisions of accident prevention regulation DGUV regulation 3 (e.g. master electrician). Corresponding regulations apply in other countries and must be observed.

2.4 Disclaimer

B.E.G. Brück Electronic GmbH is not liable in the following cases:

- The appliance is not being used as intended.
- Reasonably foreseeable misapplications are not taken into account.
- Installation and electrical connection are not carried out professionally.
- Changes (e.g. structural) that are made to the device.



3 General information

3.1 Basics of the KNX BUS

A KNX commissioning or project planning course is required to understand these instructions. To be able to work with the B.E.G. applications, they must first be imported into the ETS. ETS version 5 or higher is supported.

3.2 Symbolism

Various symbols are used in the following application description to provide a better overview. These symbols are briefly explained here.

	Attention: This symbol indicates text passages that must be read in order to avoid errors during project planning and commissioning.
	Recommendation: This symbol indicates parameter settings which experience has shown to lead to optimum utilisation of the appliance.

4 Functional description

4.1 Application

The device is a compact 230 V dimmer with 1 dimmable output and 2 binary inputs. The dimming actuator can be used for dimmable 230V light sources. To cover a wide range of usable light sources, the UAD1-230/KNXs REG can be operated with leading edge phase control or trailing edge phase control. The configuration allows control via switching telegrams, relative dimming and dimming value. Several comfort functions are also integrated, including scenes, snooze function, staircase lighting and sequencer. The inputs can be controlled via conventional switches with an external voltage of 230 V. Two buttons and three LEDs enable local operation and visualisation of the device status. In addition to the output and input channels, the device contains 16 independent logic or time functions. The device supports KNX Data Security.

4.2 Device structure

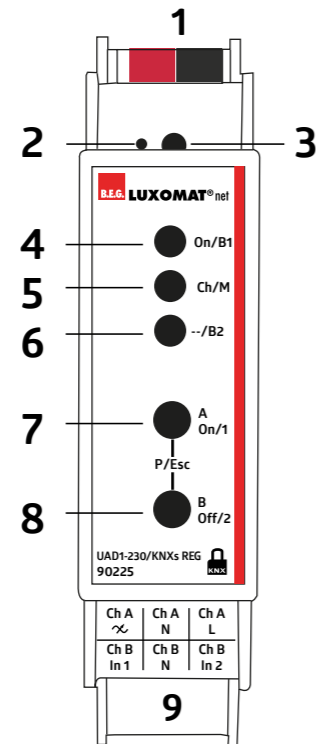

Fig. 1

1	Bus connector KNX TP
2	KNX programming LED
3	KNX button for programming mode
4	LED multicoloured On/B1
5	LED multicoloured Ch/M
6	LED multicoloured --/B2
7	Button A On/1
8	Button B Off/2
9	Plug-in screw terminals

5 Commissioning

Once the device has been installed and the bus line has been connected, the device can be put into operation. The following procedure is generally recommended.

5.1 Carry out ETS commissioning

Switch on the power supply to the device.

Before you can work with the device, the product database must first be imported into the ETS.

HINT



ETS version 5 or higher is supported.

→ Download the product database of the device from the B.E.G. website or from the ETS online catalogue.

→ Import the downloaded product database of the device into the ETS.

You can now configure the device in your project.

5.2 KNX programming mode

The KNX programming mode is **activated/deactivated** either by pressing the recessed KNX programming button **3** or by simultaneously pressing the buttons (P/Esc) **7** and **8**.

When the programming mode is active, the programming LED **2** and the LED Ch/M **5** light up red.

The operation/visualization of the programming mode on the front can be activated/deactivated in the ETS® on page general settings.

See '4.2 Device structure' on page 10.

5.3 Manual operation and status display

The LED Ch/M **5** lights up or flashes if the device is successfully powered by the KNX bus.

Pressing button **A 7** long switches to manual operation of the dimming actuator channel (channel A). This is indicated by cyclic, one-time flashing of the LED Ch/M **5** in orange.

Pressing button **B 8** long switches to manual operation of the channel pair of the binary input (channel B). This is indicated by cyclic, two-time flashing of the LED Ch/M **5** in orange.

In manual operation, the dimmer channel can be switched on by pressing the button **On 7** and switched off by pressing button **Off 8** short, dimmed brighter with long button press on **7** and darker with long button press on **8**.

Summary of the states of LED Ch/M **5**:

LED behaviour	Meaning
LED lights green	Device is working in standard operation mode
LED lights red	Programming mode is active
LED flashes 1x orange	Programming mode is not active. Manual operation is active. Switching/dimming of dimming actuator (channel A) possible
LED flashes 2x orange	Programming mode is not active. Manual operation is active. Switching of channel pair B1/B2 of binary input (channel B) possible.
LED flashes red	Programming mode is not active. Manual operation is not active. The device is not properly loaded, e.g. after an interrupted ETS download.
LED flashes green	The device is currently loaded by the ETS

The On/1 **4** indicates the status of the dimming actuator. It lights up when the channel is switched on and is off when the channel is switched off.

If manual operation is activated for the binary input, the bus telegram for In1 can be triggered via push-button **A 7**, for In2 via push-button **B 8**, if input is configured with ETS.

The LED On/1 **4** and LED --/2 **6** are used to indicate state of selected channel pair while manual operation. They light green when the button **A1 7** and **B 8** is pressed.

The manual operation mode can be exit by pressing the buttons (Esc) **7** and **8** simultaneously.

Summary of the states of the LED On/1 **4**:

LED behaviour	Meaning
LED lights red	Error condition: No auxiliary voltage is connected to the device
LED flashes red	Error condition: Overheating, Overload or Overcurrent
LED lights green	No error condition is active. Dimmer/Actuator A is switched on or Input B1 is active.
LED is off	No error condition is active. Dimmer/Actuator A is switched off or Input B1 is not active.
LED flashes orange	Device is locked: Higher current limit must be unlocked.

Summary of the LED states --/2 **6**:

LED behaviour	Meaning
LED lights green	Input B2 is active
LED is off	Input B2 is not active

6 Reset to factory settings

It is possible to reset the device to its factory default settings.

- Disconnect the KNX bus connector **1** from the device
 - Press the KNX programming button **3** and keep it pressed down.
 - Reconnect the KNX bus connector **1** to the device
 - Keep the KNX programming button **3** pressed for at least another 6 seconds
 - A short flashing of all **LEDs (2, 4, 5, 6)** visualizes the successful reset of the device to factory default settings.
- See „4.2 Device structur“ on Page 10.

In the factory default settings, the device has the physical address 15.15.255 and no group addresses are connected. Also, KNX Data Security is disabled and the initial key (FDSK) must be used for secure commissioning.

7 Connection diagram

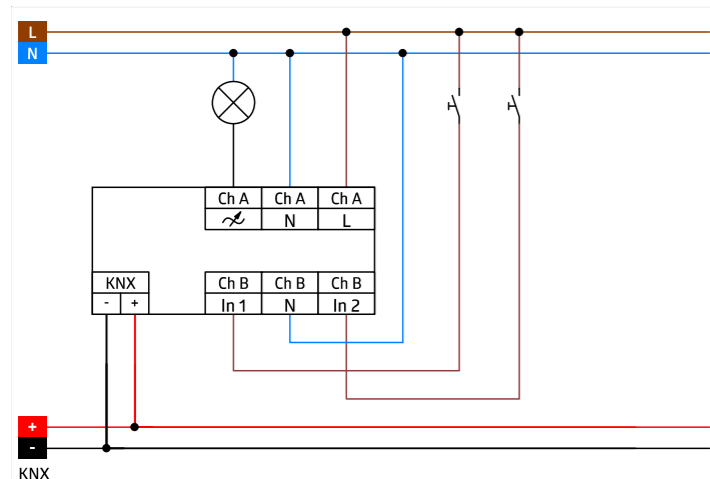

7.1 Pluggable screw terminals

Channel A is on the upper terminal and channel B on the lower terminal:

Ch A ~	Ch A N	Ch A L
Ch B In 1	Ch B N	Ch B In 2

Upper connection

The upper pluggable screw terminals 9 are used to control a 230V light source. The outer conductor is connected to the right terminal (L), the neutral conductor to the middle terminal (N). The dimmed phase of the load is connected to the left terminal (~).

Lower terminal

The assignment of the pluggable screw terminals 9 is as follows: Left input 1 (In1), right input 2 (In2), in the middle neutral conductor (N).

7.2 Pin assignment

Connection	Symbol	Description of the
1	Ch A ~	Channel A Output operated as dimmer
2	Ch A N	Channel A Neutral conductor
3	Ch A L	Channel A Outer conductor
4	Ch B In1	Channel B Input 1
5	Ch B N	Channel B Neutral conductor
6	Ch B In 2	Channel B Input 2
KNX	+	Positive connection for KNX bus
KNX	-	Ground connection for KNX bus

7.3 Operating parameters of the dimmer channel

Luminaire

The 230V LED luminaires used must be marked as dimmable. If the lamp is marked dimmable, check whether trailing or leading edge control is to be used.

HINT

!

With factory settings, the dimming channel is configured with trailing edge control. With this configuration, loads that may only be operated with leading edge control (e.g. inductive load) must not be connected.

Replacing the lamp may make it necessary to adapt the ETS configuration to the new lamp.

It may often be necessary to set the minimum brightness of the lamp, otherwise the dimmer output may be activated, but the lamp is not yet lit. In addition, LED luminaires often show a flickering in the lowest dimming range, which can be avoided by selecting a suitable dimming range. By selecting different minimum brightness levels for increasing and decreasing brightness, the characteristic dimming behavior of many available light sources can also be better exploited.

Power dissipation

The dimming of luminaires is not possible without a certain power loss in the dimmer. This power dissipation leads to a heating of the device and depends on several factors. In addition to the output of the connected lamps, the current dimming value is also taken into account. Thus, the loss with the luminaire switched off is almost zero except for the leakage current. Even at 100%, the power loss is relatively low and can be traced back to the contact resistance of the output.

Between 0 and 100%, the switching losses due to the leading or trailing edge dimming are added. Overall, there is a maximum power dissipation in the medium to upper dimming range.

A difference also results from the dimming mode. Leading edge control has a higher loss, especially with many LED luminaires. For this reason, trailing edge control is preferable for lamps that are compatible with both modes. Leading edge control should only be selected if interfering flickering is detected during dimming and this can be prevented with trailing edge control.

The max. power refers to the maximum permitted ambient temperature for free installation. If there are other devices next to the dimming actuator that emit heat, the power that can be connected is reduced. Alternatively, the devices can also be mounted at a small distance (approx. ½ TE = 9 mm). Suitable spacers for the top-hat rail are available on the market for this purpose

Power rating

The maximum power of the device is specified at 200W. This specification refers to a resistive load with trailing or leading edge control. When using LED luminaire, the following restrictions must be observed:

- Leading edge control:
Max. power 24W with max. 4 LED lamps
- Trailing edge control:
Max. power 100W with max. 10 LED lamps

The maximum values of the connected load always depend on the connected load or lamp type (the various lamps, transformers, ballasts, ...) as well as on the operating mode (leading or trailing edge control) and may be lower than the specified values.

A mixture of loads with capacitive and inductive components is not permitted.

The following sketch is used to estimate the power derating when the ambient temperature increases:

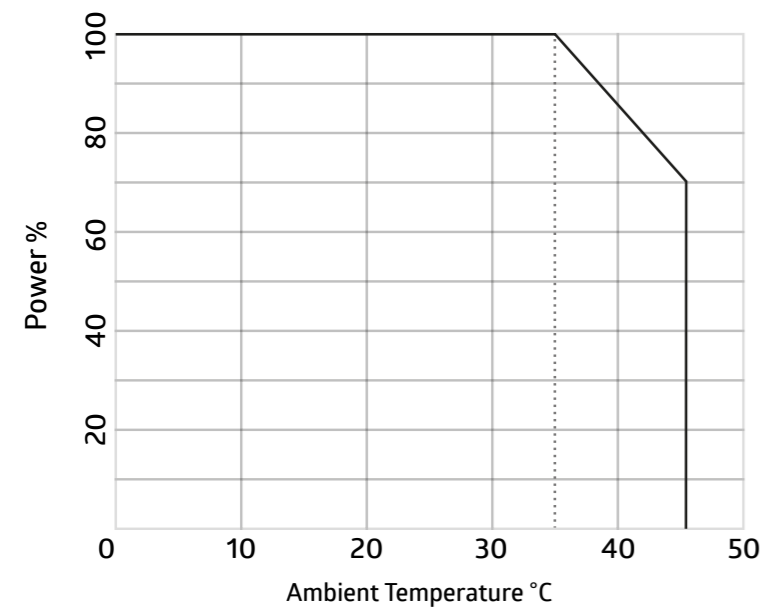
**Safety shutdown**

The dimming actuator has an electronic fuse for overcurrent and overtemperature. In both error cases, the output is switched off and can be switched on again via a command if the error is no longer present.

In addition, the device is also equipped with a fuses against overtemperature. This fuse stage protects connected devices and surrounding materials against severe damage, but leads to failure of the dimming actuator and can no longer be reset.

8 KNX Security

The KNX standard was extended by KNX Security to protect KNX installations from unauthorized access. KNX Security reliably prevents the monitoring of communication as well as the manipulation of the system.

The specification for KNX Security distinguishes between KNX IP Security and KNX Data Security. KNX IP Security protects the communication over IP while on KNX TP the communication remains unencrypted. Thus, KNX IP Security can also be used in existing KNX systems and with non-secure KNX TP devices.

KNX Data Security describes the encryption on telegram level. This means that the telegrams on the twisted pair bus or via RF (radio frequency) are also encrypted.

HINT

Encrypted telegrams are longer than the previously used unencrypted ones. For secure programming via the bus, it is therefore necessary that the interface used (e.g. USB) and any intermediate line couplers support the so called KNX Long Frames.

9 ETS database

The ETS database (for ETS 5.7 or newer) can be downloaded from the product website of the device (www.beg-luxomat.com) or via the ETS online catalogue.

The device supports KNX Data Security to protect the device against unauthorised access from the KNX bus. If the device is programmed via the KNX bus, this is done with encrypted telegrams.

9.1 Secure commissioning

If the first product is inserted into a project with KNX Security, the ETS prompts you to enter a project password.

This password protects the ETS project from unauthorized access. This password is not a key that is used for KNX communication. The entry of the password can be bypassed with „Cancel“, but this is not recommended for security reasons.

ETS requires a device certificate for each device with KNX Security that is created in the ETS. This certificate contains the serial number of the device as well as an initial key (FDSK = Factory Default Setup Key).

The certificate is printed as text on the device. It can also be scanned from the printed QR code via a webcam.

The list of all device certificates can be managed in the ETS panel Reports – Project Security.

This initial key is required to safely put a device into operation from the start. Even if the ETS download is recorded by a third party, the third party has no access to the secured devices afterwards. During the first secure download, the initial key is replaced by the ETS with a new key that is generated individually for each device. This prevents persons or devices who may know the initial key from accessing the device. The initial key is reactivated after a reset to factory default settings.

The serial number in the certificate enables the ETS to assign the correct key to a device during a download.

9.2 Secure group communication

Each object of the device can communicate either encrypted or unencrypted. The encryption is set under „Security“ in the properties of the used group address.

The setting „Automatic“ activates encryption if both objects to be connected can communicate encrypted. Otherwise encrypted communication between the objects is not possible. In the overview of communication objects in the ETS project, secured objects can be recognized by a shield symbol.

A separate key is automatically generated by the ETS for each secured group address. These keys can also be checked in the ETS panel Reports – Project Security. To enable all devices to communicate with a secure group address, the keys must be known to all. Therefore a download must be made into all devices that use this group address when a key is created or changed. A key is changed by the ETS e.g. when the encryption of a group address is switched off and on again.

10 General settings

10.1 Device name (30 characters)

An arbitrary name can be assigned for the KNX IO 530.1 secure. The device name should be meaningful, e.g. “Living Room”. This helps the clarity of the ETS project.

General settings	
Device name	... [max. 30 characters]

10.2 Send delay after bus power return

A send delay of telegrams after the return of the bus voltage can be set via this parameter. In this case, telegrams from the device are sent to the KNX bus in a delayed manner by the set time. This results in a reduction of the bus load at a bus power return. Other functions such as receiving telegrams of switching operations of the actuator are not affected by this parameter.

General settings	
Transmission delay after bus voltage recovery	... [5 sec.]

10.3 Prog. mode on device front

In addition to the normal programming button **3**, the device allows activating the programming mode on the device front without opening the switchboard cover. The programming mode can be activated and deactivated via pressing simultaneously both buttons **7** and **8**.

This feature can be enabled and disabled via the parameter “Prog. mode on device front”. The recessed programming button **3** (next to the Programming LED **2**) is always enabled and not influenced by this parameter.

General settings	
Prog. Mode on front panel	Deactivated
	Activated

10.4 Manual operation on device

This parameter is used to configure the manual operation on the device. The manual operation mode can be disabled or activated (with or without time limitation). The time limit defines the duration until the automatic return from the manual operation mode back into the normal operating mode.

The device is in normal operating mode when the manual control is not active. In the manual operating mode, received switching telegrams are ignored. When the manual operation mode is terminated (after expiry of the time limit or manually), the last state of the outputs remains, until a new switching telegram is received again.

General settings	
The following options are selectable	Disabled
	Enabled with time limit 1 min
	Enabled with time limit 10 min
	Enabled with time limit 30 min
	Enabled without time limit

10.5 Heartbeat

Cyclic sending of values to the KNX-Bus, to indicate that the device is operational. For the Cycle time values between 1 min and 24h are selectable.

Group object	Type KNX	Size	Direction
GO 1 Heartbeat - Trigger	1.001	1 Bit	To KNX

10.6 Operating mode

The operating mode of the output can be selected here, dimmer or switching actuator is available:

Alarm Objects for error conditions

With this parameter, the following objects for the visualization of error states become visible:

Group object	Type KNX	Size	Direction
GO 2 Alarm - Overload	1.001	1 Bit	To KNX
GO 3 Alarm - Overtemperature	1.001	1 Bit	To KNX
GO 4 Alarm - No supply voltage	1.001	1 Bit	To KNX

If an error condition is detected, the dimmer output switches off and an ON telegram is sent via the respective object. The output is disabled for the duration of the error state, if it is resolved, the respective object sends an OFF telegram, and the dimmer can be used normally again.

Overload is triggered from a load of 8A, overtemperature from a measured temperature of 85°C in the load section. If no value is received by the load section for longer than 3 seconds, the error state "No supply voltage" is triggered.

10.7 Long button press after

Here the time for detection of a long actuation can be set, this time is valid for all input channels of the binary input.

General settings	
Long operation from	... [1.2 sec.]

10.8 Logic / Timer

The additional function in "13 Logic / Timer" can be activated here

11 Operating mode dimmer

The following settings are available in the operating mode dimmer:

11.1 Diagnostics

For diagnostic purposes, the controller data can be read during runtime using the „Refresh“ button.

Following general information is available:

- **Mains state:** Shows if mains power is connected
- **Overtemperature:** Indicates whether an overtemperature (> 85 °C) has been triggered
- **Temperature [°C]:** Shows measured temperature
- **Timestamp:** Shows timestamp of last refresh

Channel A: Dimmer

Following information/function is available:

- **State:** Shows if dimmer is active and the current brightness
- **Brightness:** Brightness for dimmer
- **Set value:** Sets the selected "Brightness" to dimmer
- **Off:** Turn off dimmer

Channel B: Input 1/2

Shows state of binary input

11.2 Dimmer A: General

Name (30 characters)

An arbitrary name can be assigned for the channel. However, this should be clear and meaningful, this makes it easier to work with the associated group objects, because the given name is displayed there as a label. If no name is assigned, the group objects are named "Dimmer A".

Function

This parameter defines the functionality of the actuator, the following options are selectable:

- **Disabled**
- **Dimmer**
When this functionality is selected, scene function, automatic mode, slumber and lock function are available. In the „Dimmer“ function, objects for switching on/off, relative dimming, dimmer control via dimming and RGB value can be configured. The parameter page „Dimmer A: Dimmer“ is displayed.
- **Staircase function**
The parameter page „Dimmer A: Staircase function“ is displayed. Only the lock function is available here.

When a function is selected, the following parameters appear.

Send state

This parameter defines the behavior of the state objects:

- Disabled
State objects are deactivated and not displayed
- Only on read
State objects send only on request.
- On change
The switch object sends an OFF telegram when the output value changes to 0%, an ON telegram when the output value changes from 0% to a value greater than 0%. The value object transmits with a time interval of at least 1 second if the value at the output has changed by at least 1% or if a dimming process has been completed.
- **Cyclically and on change**
State objects send cyclically and on value change.

Group object	Type KNX	Size	Direction
GO 16 Dimmer A: Dimming output - State On/Off	1.001	1 Bit	To KNX
GO 17 Dimmer A: Dimming output -State value	5.001	1 Byte	To KNX

Time for cyclic state

With this parameter, the cycle time can be set, when "Cyclic and on change" is selected for sending state.

Behavior on bus power failure

The behavior of the output in the event of bus power failure can be configured here.

The following options are selectable:

- No reaction
- Dim to value
A parameter for adjusting the value appears

Behavior after bus power return

Here the behavior of the output after bus power return can be configured. This behavior will be set after every device restart (e.g. also on restart after ETS download).

The following options are selectable:

- No reaction
- Dim to value
A parameter for adjusting the value appears.
- State like before bus power failure

Dimming method

This parameter determines the dimming mode, trailing edge and leading edge are available for selection, for further information on selecting the appropriate dimming mode, see section „4. Operating parameters of dimmer channel“.

Scene function

The scene function can be activated or deactivated here; it is only available in the „Dimmer“ operating mode. If this function is activated, the parameter page „Dimmer A: Scene function“ appears for further configuration of scenes 1-16. The further functionality is explained in section G.

Automatic mode

Automatic mode is only available in the „Dimmer“ function. If this mode is selected, the following objects become visible:

Group object	Type KNX	Size	Direction
GO 19 Dimmer A: Automatic Mode - Activate	1.001	1 Bit	From/to KNX
GO 20 Dimmer A: Autom. dimming abs. - Set value	5.001	1 Byte	From KNX

When using automatic mode, the dimmer can be controlled via object 20, e.g. for light control or daylight-dependent basic lighting.

In automatic mode, the dimmer can be manually overridden by dimming on/off, dimming rel., dimming value, scene, slumber function or sequencer. During manual override, values of object 20 are ignored, each manual override restarts the fallback time.

After the fallback time set in the parameter has elapsed, the values received on object 20 are processed again.

Via object 19, the automatic can be switched on or off at any time, it also serves as a state object for automatic mode.

Slumber function

The slumber function is only available in the „Dimmer“ operating mode. The slumber function offers 2 different fade times each for switching on and off via object. If this function is activated, a new parameter page appears, which is explained in section H.

Lock function

The lock function can be activated or deactivated here.

This function is available in both „Dimmer“ and „Staircase function“ operating modes. If this function is activated, a new parameter page appears for further configuration, which is explained in Section I in more detail.

11.3 Dimmer A: Dimmer

Object Dimming on/off

For switching the dimmers, the following object is available, if it has been activated via parameters:

Group object	Type KNX	Size	Direction
GO 11 Dimmer A: Dimming on/off - Switch	1.001	1 Bit	From KNX

Behavior on ON telegram (when dimmer is off)

If the dimmer is switched off, this parameter can be used to configure the behavior when switching on via object 11. It is available:

- No reaction
- Dim to fix value
- Dim to last value before switching off

Behavior on ON telegram (when dimmer is on)

If the dimmer is already switched on, this parameter can be used to configure the behavior for a new ON telegram via object 11.

It is available:

- No reaction
- Dim to fix value
- Dim to fix value if higher than actual

Dimming value on ON telegram

This value is activated by ON telegram via object 11 with suitable parameterization.

Fade time on ON telegram

This fade time is active when an ON telegram is received. The period refers to a complete dimming process of 0-100%.

Behavior on OFF telegram

This parameter describes the behavior of the dimmer when an OFF telegram is sent via object 11.

It is available:

- No reaction
- Dim to fix value

Dimming value on OFF telegram

This value is activated by OFF telegram via object 11 with suitable parameterization.

Behavior on 2. OFF telegram

This parameter describes the behavior of the dimmer when a 2. OFF telegram is received via object 11.

It is available:

- No reaction
- Switch off

The 2. OFF telegram must follow the 1. OFF telegram within 1 second in order to be evaluated. If the current brightness is equal to or lower than the parameterized brightness for OFF telegram, the device is already switched off by the 1. OFF telegram.

Fade time on OFF telegram

This fade time is active when an OFF telegram is received. The period refers to a complete dimming process of 0-100%.

Day/night switching

When using this function, the following objects are visible for switching between day/night mode:

Group object	Type KNX	Size	Direction
GO 15 Dimmer A: Day/Night - Switch	1.001	1 Bit	From KNX

Day mode is triggered with an ON telegram on object 15, night mode with an OFF telegram. After a restart, the device is in day mode.

In addition, it can be determined when the values become active after receiving a telegram on these objects, it is available:

- Disabled
- Switch on day/night telegram
Immediately after reception of day/night switching, it is dimmed to the active value according to the last switch-on/switch-off received via object 11.
- Switch on next on/off telegram
The currently active value is not used until the next switch on/off telegram via object 11

There is a separate switch-on and switch-off value for night mode in the parameters, in day mode the always visible values are used

Dimming value on ON telegram (night)

If the dimmer is in night mode, this value is activated by ON telegram via object 11 and suitable parameterization.

Dimming value on OFF telegram (night)

If the dimmer is in night mode, this value is activated by OFF telegram via object 11 and suitable parameterization.

Fade time for day/night switching

This fade time is only active if switching on day/night telegram is used. If switching on next on/off telegram is used, the regular fade time of the respective on or off telegram is active. The period refers to a complete dimming process of 0-100%.

Object Dimming rel.

The following object is available for dimming using relative dimming commands, if activated via parameters:

Group object	Type KNX	Size	Direction
GO 12 Dimmer A: Dimming rel. - Brighter/Darker	3.007	4 Bit	From KNX

Minimal dimming value when switching on dimmer with object

When a dimming value >0% is received, the value set here is jumped to if the current dimming value is below the minimum dimming value when switching off. If the received value is greater than the value set here, the brightness is increased until the telegram value or the maximum brightness is reached.
For further information on setting this parameter, see section „7. Operating parameters of dimmer channel“.

Minimal dimming value when switching off dimmer with object

This parameter determines the minimum dimming value that can be achieved by reducing the brightness via the dimming value. For further information on setting this parameter, see section „7. Operating parameters of dimmer channel“. If a value >0% is set here, the following parameter is also visible:

Switch off dimmer by object

Here it can be set whether the dimmer can be switched off via object 13:

- Disabled
When receiving a telegram value smaller than the minimum dimming value when switching off, the dimmer is controlled with the set minimum value.
- With telegram value below minimal value
When receiving a telegram value smaller than the set minimum dimming value when switching off, the dimmer switches off.
- With telegram value 0%
When a telegram value of 0% is received, the dimmer switches off, otherwise the dimmer is controlled with the minimum value if a telegram value smaller than the set minimum dimming value when switching off is received

Maximal dimming value for changing dimming value with object

This parameter can be used to configure which maximum dimming value can be reached via object 13. If a value above the maximum value is received, the dimmer is controlled with the maximum value.

Fade time while dimming brighter with object

This fade time is active when the brightness is increased by relative dimming with object 13. The period refers to a complete dimming process of 0-100%.

Fade time while dimming darker with object

This fade time is active when the brightness is decreased by relative dimming with object 13. The period refers to a complete dimming process of 0-100%.

Object RGB value

To control the dimmer via RGB color value, the following object is available, if activated via parameter:

Group object	Type KNX	Size	Direction
GO 14 Dimmer A: RGB color value - Set value	232.600	3 Byte	From KNX

RGB value usage

Here it is set how a received RGB color value is to be processed:

- Use red part
The 1. byte of the RGB value (red) is used to control the brightness of the dimmer.
- Use green part
The 2. byte of the RGB value (green) is used to control the brightness of the dimmer.
- Use blue part
The 3. byte of the RGB value (blue) is used to control the brightness of the dimmer.
- Use white (min. value of red, green, blue)
The smallest value of the 3 bytes is used to control the brightness of the dimmer.
- Use brightness (max. value of red, green, blue)
The largest value of the 3 bytes is used to control the brightness of the dimmer.

Minimal value for changing color by object

Minimal value for changing color by object.

Maximal value for changing color by object

This parameter can be used to configure which maximum dimming value can be set via object 14. If a value above the maximum value is received, the dimmer is controlled with the maximum value.

Fade time while dimming brighter with object

This dimming time is active when the brightness is increased by values received via object 14. The time period refers to a complete dimming process of 0-100%.

Fade time while dimming darker with object

This dimming time is active when the brightness is decreased by values received via object 14. The time period refers to a complete dimming process of 0-100%.

11.4 Dimmer A: Staircase function

This parameter page can be used to implement a staircase function with optional orientation light. The staircase function can be overridden by the lock function. It has the following objects:

Group object	Type KNX	Size	Direction
GO 11 Dimmer A: Staircase function - Trigger	1.010	1 Bit	From KNX
GO 15 Dimmer A: Day/night switching	1.001	1 Bit	From KNX

Day mode is triggered with an ON telegram on object 15, night mode with an OFF telegram. After a restart, the device is in day mode.

Dimming value on switching on the staircase function (day)

This value is used in day mode when the staircase function is switched on via ON telegram to object 11.

Dimming value on switching on the staircase function (night)

This value is used in night mode if the staircase function is switched on via On telegram on object 11.

Fade time for switching on

This dimming time is active when the staircase function is switched on via ON telegram to object 11. The period refers to a complete dimming process of 0-100%.

Delay time for staircase function

After the delay time has elapsed, the dimmer is dimmed to the switch-off or orientation light value depending on the parameter setting.

Reaction on ON telegram

This parameter determines the behavior after switching on the staircase function via ON telegram on object 11: When „Switch on“ is set, the channel remains switched on after ON telegram until the follow-up time is started via OFF telegram. In the setting „Switch to delay time“, the channel enters the delay time immediately after the ON telegram.

Delay time retriggerable

If it is set that the delay time is started with ON telegram, this parameter determines whether only the 1. ON telegram on object 11 starts the delay time, or also any further.

If it is set that the delay time is started with OFF telegram, this parameter determines whether only the 1. OFF telegram on object 11 starts the delay time, or also any other if the staircase function is already in the delay time.

Orientation light after delay time

This parameter can be used to set whether the dimmer dims to switch-off value or to orientation light at the end of the delay time, as well as the duration of the orientation light.

It is available:

- Disabled
- 1 s
- 2 s
- 5 s
- 10 s
- 30 s
- 1 min
- 2 min
- 5 min
- 10 min
- 20 min
- 30 min
- 1 h
- 2 h
- Without time limit

Dimming value while orientation light

This value is dimmed to at the end of the delay time when orientation light is used.

Fade time for orientation light

This fade time is active when the staircase function dims to orientation light. The period refers to a complete dimming process of 0-100%.

Reaction on OFF telegram

Here it can be set how the staircase function behaves in the event of an OFF telegram. The following options are available:

- Ignore
No reaction of the channel on OFF telegram
- Switch off
Switch to switch-off value from the parameters
- Switch to switch-off delay
The delay time is started with OFF telegram.
- Switch to orientation light
The orientation light phase is started with OFF telegram
- Switch to orientation light/switch off
With 1. OFF telegram the orientation light phase is started, with 2. OFF telegram it is dimmed to switch-off value.

Dimming value on switching off the staircase function (day)

This value is dimmed to in day mode if the staircase function is switched off after the delay time or via OFF telegram on object 11.

Dimming value when switching off the staircase function (night)

This value is dimmed to in night mode if the staircase function is switched off after the delay time or via OFF telegram on object 11.

Fade time for switching off

This fade time is active when the staircase function dims to the switch-off value. The period refers to a complete dimming process of 0-100%.

11.5 Dimmer A: Dimming curve

This parameter page is used for fine adjustment of the dimmer to different light sources.

HINT	
	All parameters on this page only affect the PWM value of the output, not the dimming or output status value

Dimming curve

Here it can be specified which PWM values are output by the dimming outputs when the dimming channel has reached a certain dimming value. The following options are available:

- Linear
- Logarithmic
- User defined
- Gamma
Gamma correction according to the formula:
 $PWM\ value = \text{Gamma}^{\text{dimming value}}$
Gamma can be set via parameters from 1.00..5.00.

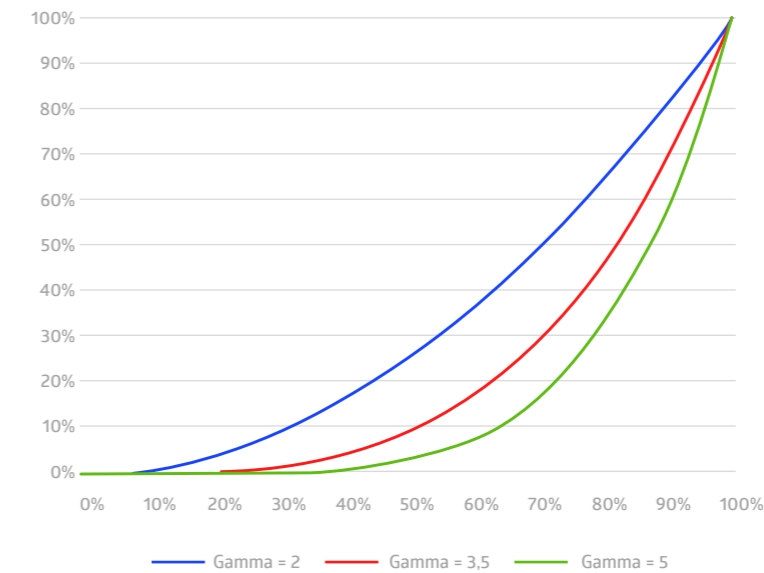

- DALI
Function based on DALI with the formula:
 $PWM\ value = 10^{3(\text{dimming value} - 1)}$

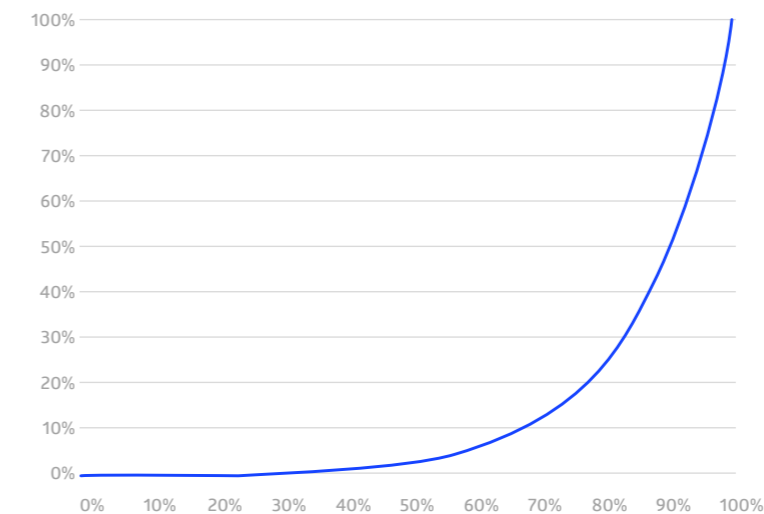

Dimming output at x%

For the „Linear“, „Logarithmic“ and „User defined“ dimming curves, these values determine the PWM values of a dimming output at the specified dimming value. Values between the specified points are calculated and output linearly. As an example, a dimming output with dimming curve „Logarithmic“ behaves according to the following graph:

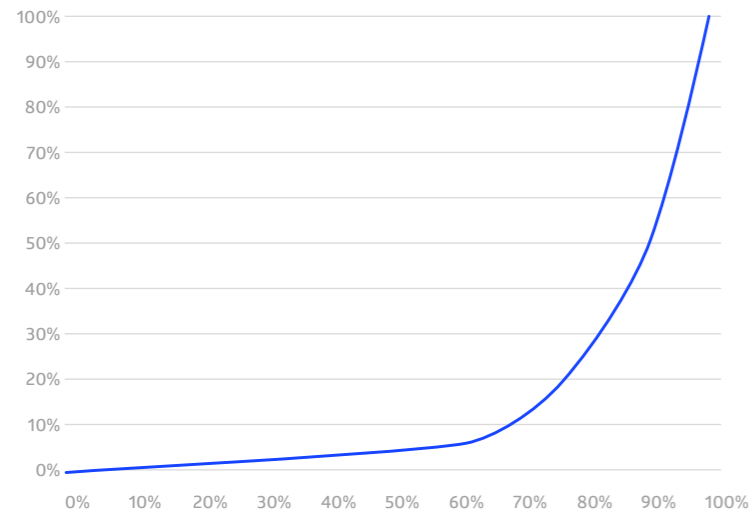

The output values are fixed for the „Linear“ and „Logarithmic“ dimming curves, and can be freely configured for the „User-defined“ curves.

HINT

! If a dimming value of 0% is reached, the channel always switches off.

Adjustment of channel

The PWM value of the calculated value by the dimming curve is additionally scaled with this value.

Offset

This offset is added to all calculated PWM values of the dimming curve except 0%.

11.6 Dimmer A: Scene function

If the scene function is activated, the following group objects appear:

Group object	Type KNX	Size	Direction
GO 18 Dimmer A: Scene - Activ./Lrn.	18.001	1 Byte	From KNX

Fade time on activation of scene

Here the period can be set in which the received scene is dimmed to. The period refers to a complete dimming process of 0-100%.

Scene 1-16

These parameters can be used to configure the reaction of the channel when the respective scene is received.

It is available:

- No reaction
- Dimming value
The output is switched to the set dimming value if the scene of the corresponding number was received.
- Learnable
With the help of a scene control telegram, the current state at the output for the respective scene can be saved here. Thus the scene can be adapted by the user without ETS download

Number

With this parameter any scene number between 1 and 64 can be assigned to the scene. No scene numbers may be assigned twice.

11.7 Dimmer A: Slumber function

If the slumber function is active, the following objects are visible:

Group object	Type KNX	Size	Direction
GO 21 Dimmer A: Slumber function - Trigger	1.001	1 Bit	From KNX

Target value while switching on the slumber function

This value is reached by the channel after completion of the dimming process after receiving an ON telegram via object 21.

Target value while switching off the slumber function

This value is reached by the channel after completion of the dimming process after receiving an OFF telegram via object 21.

Fade time on 1. ON telegram (1. button press)

This fade time is used to dim to the target value for switching on after the 1. button press. The period refers to a complete dimming process of 0-100%.

Fade time on 2. ON telegram (2. button press)

This fade time is used to dim to the target value for switching on after the 2. button press. The period refers to a complete dimming process of 0-100%.

Fade time on 1. OFF telegram (1. button press)

This fade time is used to dim to the target value for switching off after the 1. button press. The period refers to a complete dimming process of 0-100%.

Fade time on 2. OFF telegram (2. button press)

This fade time is used to dim to the target value for switching off after the 2. button press. The period refers to a complete dimming process of 0-100%.

11.8 Dimmer A: Lock function

If the lock function is activated, the following objects are active

Group object	Type KNX	Size	Direction
GO 22 Dimmer A: Lock - Activate	1.001	1 Bit	From KNX
GO 23 Dimmer A: Prior. dimming on/off - SwitchSwitching	1.001	1 Bit	From KNX
GO 24 Dimmer A: Prior. dimming rel. - Brighter/Darker	3.007	4 Bit	From KNX
GO 25 Dimmer A: Prior. dimming abs. - Set value	5.001	1 Byte	From KNX

If the lock was activated by object 22, other received telegrams for dimmer, automatic mode, slumber, scene function and sequencer are not executed.

In addition to the lock object, 3 priority objects become visible when the lock function is activated, with which the dimmer can be controlled independently of the lock. This makes it possible to set an initial state without affecting other functions.

Example of the priority objects:

In the case of events in public buildings or in restaurants, the normal operation can be set into an inoperative state by the lock group object. Thus it is possible to lock during the lecture or concert, switches that are accessible to unauthorized persons, in order to prevent unmeant switching. Nevertheless, the individual lamps can be controlled by use of the priority object without canceling the lock.

Polarity of object

This parameter defines, if the lock should be activated by receiving a 1 or by receiving a 0.

The following options are selectable:

- Lock active at 1
- Lock active at 0

Behavior on start

This parameter configures, which state the output should set, if the lock activates.

The following options are selectable:

- No reaction
- Dim to value
A parameter for adjusting the value appears

This output state can still be changed by the priority object.

Behavior at end

This parameter defines, which state the output should set, if the lock deactivates.

The following options are selectable:

- No reaction
- Dim to value
A parameter for adjusting the value appears.
- State before lock
This restores the original state before the lock was activated. Telegrams received during the lock are ignored.
- State without lock
Here the state of the last received telegram is restored. This takes into account the received telegrams during the lock. Thus, when the lock is deactivated, the last received telegram is set.

11.9 Dimmer A: Sequencer

The sequencer can be used to create complex sequence programs consisting of up to 32 individual steps for the dimmer channel. The individual steps can be activated under the following starting conditions:

- At a fixed time of day
- After a waiting time from a previous step has elapsed
- By on/off telegram
- When receiving a parameterized scene number

When a step is activated, a value can be dimmed to or a scene number can be sent, and a step or a whole sequence of steps can be repeated cyclically.

The following objects are available for the general control of the sequencer:

Group object	Type KNX	Size	Direction
GO 33 Dimmer A: Sequence suspend - Suspend/Resume	1.001	1 Bit	From KNX
GO 34 Dimmer A: Sequence on/off - Switch	1.001	1 Bit	From KNX

The following parameters determine the general behavior of the sequencer:

Steps of sequencer

Number of steps (0...32) to be used

Resume sequence after man. operation

An activated sequence can always be interrupted or continued via object 33 an ON telegram interrupts the sequence, and with an OFF telegram it is continued.

A sequence is also interrupted after manual operation, i.e. after commands for dimmer, automatic mode, slumber or scene function.

In addition, this parameter determines how an interrupted sequence can still be continued:

- Only by object
The sequence can only be continued by object 33.
- After off-time
The sequence is continued after the set off-time.
- On next activated step
The sequence is continued with the next activated step, the next step can be activated by object or time-controlled.

Off-time

Only visible if the sequence is to be continued after off-time, with this parameter the off-time can be configured.

Step after man. operation

This step is executed when resuming after manual operation, the function of the set step is always executed, regardless of its otherwise set starting conditions.

Polarity of object "Sequence on/off"

This parameter can be used to set the telegram value with which the sequence can be switched on and off via object 34. If the sequence is switched off, any further activation of a step is disabled.

Behavior on switching on

Here it is determined how the sequencer behaves when switched on by object 34:

- No reaction
No function is executed, the sequencer waits for steps to be activated.
- Step x
The function of the step is executed (independent of the other set start conditions of the step), the sequence is then continued according to its configuration from this step onwards.

Switching on also reactivates a sequence interrupted by manual operation.

Behavior on switching off

Here it is determined how the sequencer behaves when switched off by object 34:

- Complete actual step
If the sequencer is in a dimming process, it is completed.
- Step x
The function of the step is executed (independent of the other set start conditions of the step).
- Stop immediately
If the sequencer is in a dimming process, it is stopped.

Apart from the set behavior when switching off, any further activation of a step after switching off is disabled until the sequencer is switched on again by object 34.

Step 1-32:

When a step is activated, its parameters for configuration appear.



In the text box at the top right with the content „Step x“, you can enter your own name for the step. This designation serves for better orientation of the user and has no influence on the function of the step.

Start by time

This parameter is used to configure a temporal start condition of the step.

- Disabled
Start condition not used
- Start at a fixed time of day
Here the time of day at which the step should start can be entered. When using this start condition, the current time must have been received via the following object:

Group object	Type KNX	Size	Direction
GO 5 Time of Day - Set	10.001	3 Byte	From KNX

HINT	
	If no valid time was received by object 5, all start conditions at fixed times of day are not active.
	The time is continuously updated by the device through its internal timers, but component tolerances always result in a deviation from the actual time. Therefore, the current time should be sent to the device by a precise timer at least twice a day in order to keep the deviation as small as possible.

- Start after last trigger
Here you can specify the time interval to wait after the previous activation before executing the step. This start condition is not available for step 1.

Start time

Here either the time day or the waiting time can be specified for the execution of the current step, if a timed start condition is used.

Start by ON/OFF telegram

When using this start condition, a separate object is available for each step:

Group object	Type KNX	Size	Direction
GO 35-66 Dimmer A: Sequence Step x on/off - Switch	1.001	1 Bit	From KNX

An ON telegram to one of these objects activates the respective step, the sequence is then continued according to its configuration from this step onwards.

An OFF telegram also activates this step, but resets the sequence at the same time.

Start by scene number

When using this start condition, the following object becomes visible:

Group object	Type KNX	Size	Direction
GO 31 Dimmer A: Sequence scene - Activate step	18.001	1 Byte	From KNX

A telegram with the set scene on this object activates the respective step, the sequence is then continued according to its configuration from this step onwards.

All steps with this start condition are controlled by this object.

Action

When the step is activated, the configured function is executed, the following functions are available for selection:

- None
No function is executed, for example this can be used to implement a switch-on delay for a sequence.
- Start loop
The sequence continues from the selected step. Parameters for the initial step of the loop and the number of loops become visible.
- Send scene number

When using this function, the following object becomes visible:

Group object	Type KNX	Size	Direction
GO 32 Dimmer A: Sequence Scene - Send scene	18.001	1 Byte	To KNX

- A parameter for the scene number to be sent becomes visible. When the step is activated, this scene number is sent via the object.
- All steps send the scene number via this object, if this function is used for the respective step.
- Brightness
Parameters for brightness and fade time become visible. When this step is activated, the dimmer dims from the current brightness value to the specified brightness with the parameterized fade time. This time is related to a complete dimming process of 0-100%.

12 Operating mode switching actuator

The following settings are available in the operating mode switching actuator:

12.1 Diagnostics

For diagnostic purposes, the controller data can be read during runtime using the „Refresh“ button.

Following general information is available:

- **Mains state:** Shows if mains power is connected
- **Overtemperature:** Indicates whether an overtemperature (> 85 °C) has been triggered.
- **Temperature [°C]:** Shows measured temperature
- **Timestamp:** Shows timestamp of last refresh

Channel A: Actuator

Following information/function is available

- **State:** Shows if actuator is active
- **On/Off:** Switches actuator

Channel B: Input 1/2

Shows state of binary input

12.2 Actuator A: General

Name (30 characters)

An arbitrary name can be assigned for the channel. However, this should be clear and meaningful, this makes it easier to work with the associated group objects, because the given name is displayed there as a label. If no name is assigned, the group objects are named “Actuator A: ...”.

Function

This parameter defines the functionality of the actuator.

The following options are selectable:

- Universal output
- On/Off delay
- Staircase function
- Valve actuator (PWM for thermal servo)

If the actuator is not “Disabled”, the following parameters are displayed:

Behavior after bus power return

The behavior which is held at the output during the bus power failure can be configured here.

The following options are selectable:

- No reaction
- Switch on
- Switch off

Behavior after bus power return

Here the behavior of the output after bus power return can be configured. This behavior will be set after every device restart (e.g. also on restart after ETS download).

The following options are selectable:

- No reaction
- Switch on
- Switch off
- State like before bus power failure

Send state

This parameter defines the behavior of the state objects:

- Disabled
State objects are deactivated and not displayed
- Only on read
State objects send only on request
- On change
State objects send on value change
- Cyclic and on change
State objects send cyclically and on value change

Group object	Type KNX	Size	Direction
GO 18 Actuator A: Output - State	1.001	1 Bit	To KNX
GO 19 Actuator A: Valve actuator (PWM) - State*	5.001	1 Byte	To KNX

* if valve actuator was selected

Time for cyclic state

Is selected state object “Cyclic and on change”, in this parameter the cycle time can be set.

Lock function

With this parameter the lock function can be enabled. If this functionality is activated, the associated group objects as well as the parameter page “Actuator A: Lock function” are displayed for further configuration. If the lock has been activated via the group object „Lock”, the received switching telegrams are not executed.

In addition to the lock object, there is also a priority object, which can be switched independently of the lock. Thus, it is possible to set an output state without affecting other functions.

Group object	Type KNX	Size	Direction
GO 15 Actuator A: Lock - Activate	1.001	1 Bit	From KNX
GO 16 Actuator A: Prior. output - Switch	1.001	1 Bit	From KNX

Example of the priority object:

In the case of events in public buildings or in restaurants, the normal operation can be set into an inoperative state by the lock group object. Thus it is possible to lock during the lecture or concert, switches that are accessible to unauthorized persons, in order to prevent unmeant switching. Nevertheless, the individual lamps can controlled by use of the priority object without canceling the lock.

12.3 Actuator A: Lock function

Polarity of object

The following options are selectable:

- Lock active on 1
- Lock active on 0

Behavior on start

This parameter configures, which state the output should set, if the lock activates.

The following options are selectable:

- No reaction
- Switch on
- Switch off

This output state can still be changed by the priority object

Behavior at end

This parameter defines, which state the output should set, if the lock deactivates.

The following options are selectable:

- No reaction
- Switch on
- Switch off
- State before lock
This restores the original state before the lock was activated. Switching telegrams received during the lock are ignored.
- State without lock
Here the state of the last received switching telegram is restored. This takes into account the received switching telegrams during the lock. Thus, when the lock is deactivated, the last received switching telegram is set

Function (Universal output)

If the universal output is selected on the parameter page „Actuator A: General“, the actuator can be used as a switching output. A parameter for the scene function is also displayed.

Group object	Type KNX	Size	Direction
GO 11 Actuator A: Output - Switch	1.001	1 Bit	From KNX

Scene function

With this parameter the scene function can be enabled or disabled. If this functionality is enabled, the respective group object as well as the parameter page „Actuator A: Scene function“ are displayed for further configuration of scenes 1-16.

Group object	Type KNX	Size	Direction
GO 12 Actuator A: Scene - Activ./Lrn.	18.001	1 Bit	From KNX

12.4 Actuator A: Scene function

Scene 1-16

These parameters can be used to configure the state, which is set at the output when the respective scene is executed.

The following options are selectable:

- No reaction
- Switch on
- Switch off
- Learnable

By using a scene control telegram, the current state at the output can be saved for the respective scene. This allows the user to customize the scene without ETS download.

Number

This parameter sets any scene number between 1 and 64 to the scene. There must not configured any scene numbers twice.

Function (On/Off delay)

If the ON/OFF delay is selected on the parameter page „Actuator A: General“, delayed switching times can be configured. The „Actuator A: On/Off Delay“ parameter page is displayed for this purpose.

Group object	Type KNX	Size	Direction
GO 11 Actuator A: Output - Switch	1.001	1 Bit	From KNX

12.5 Actuator A: On/Off delay

On delay time

The duration of the switch-on delay is configured in this parameter.

Input -----1-----0-----

Output -----|T-1-----0-----

Off delay time

The duration of the switch-off delay is configured in this parameter.

Input -----1-----0-----

Output -----1-----|T-0-----

Retriggerable

If these parameters are activated, the respective delay time is restarted upon receipt of the corresponding switching signal.

Function (Staircase function)

If the staircase function is selected on the parameter page „Actuator A: General“, a group object for the staircase function appears in addition to the normal switching object. Via the additional parameter page „Actuator A: Staircase function“ this function can be configured.

Group object	Type KNX	Size	Direction
GO 11 Actuator A: Output - Switch	1.001	1 Bit	From KNX
GO 13 Actuator A: Staircase function - Trigger	1.010	1 Bit	From KNX

12.6 Actuator A: Staircase function

Switch off time

The time for which the output is activated after an ON telegram (object of the staircase function) has been received, can set in this parameter.

Input -----1-----0-----
Output -----1-T-0-----

Retriggerable

This parameter can be used to set whether the follow-up time is to be restarted when an ON telegram is received on the object of the staircase function.

Reaction on 'OFF' telegram

This parameter can be used to set whether an OFF telegram on the object of the staircase function should be processed or ignored.

Time for warning before switch off

The time between pre-warning and deactivation is configured, or the pre-warning is deactivated with this parameter. If the pre-warning time is longer than the actual follow-up time, no pre-warning is carried out.

Time of interrupt

The pre-warning is indicated by a brief interruption (switch off -> switch on). The duration of this interrupt is configured in this parameter.

HINT	
	LED lamps often have a long follow-up time, in which the lamp still lights even though it is already switched off. With such lamps longer interrupt times must be set to generate a „visible“ interruption.

Function (Valve actuator)

The function valve actuator is foreseen to control thermoelectric valve drives which are used for floor heating but also for radiators. It maps the continuous position (0% - 100%) to an ongoing On/Off sequence called PWM (pulse width modulation) signal.

If the valve actuator is selected on the parameter page „Actuator A: General“, a group object for the valve actuator appears instead of the normal switching object. This allows the current PWM at the output to be set via KNX (0% - 100%). An additional parameter page „Actuator A: Valve actuator“ appears for the configuration of the valve actuator. The received control value is saved automatically by the device, to continue faultless after a possible bus power loss.

Group object	Type KNX	Size	Direction
GO 14 Actuator A: Valve actuator (PWM) - Control value	5.001	1 Byte	From KNX

12.7 Actuator A: Valve actuator

Cycle time (PWM)

The cyclic time of the PWM, which is used to control a servo drive, is configured with this parameter. One cycle involves a time range in which the output is switched on and one in which the output is switched off. The cyclic time corresponds to the period between two rising edges (state change at the output from OFF to ON). The longer the flow of the heating circuit (tube / pipe length), the higher the cyclic time should be set.

HINT	
	Typical thermal servos require several minutes for a 100% valve change.

Maximum control value (PWM)

This parameter can be used to limit the maximum control value. The control value is expressed in percent and defines the period during which the output is switched on in one cycle.

Example:

Cyclic time = 10 min.

Maximum actuating value (PWM) = 80 %

Maximal output state = ON - 8 min. / OFF - 2 min.

Stuck protection

With the stuck protection, it is intended to prevent the valve from being damaged by corrosion or calcification, that it can no longer be moved. In case stuck protection is enabled, this is only triggered if the value is permanently 0% or 100%. On every other control value the servo already moves, so there is no need for a stuck protection.

Control value 0% → Open servo for the set time

Control value 100% → Close servo for the set time

In case the valve is not allowed to open, the stuck protection must be disabled.

Execution time

If the stuck protection is activated, this parameter is used to set the duration of the state change.

Monitoring interval

If the stuck protection is activated, this parameter sets the monitoring interval. If the state of the output remains unchanged for this time, the lock protection is triggered.

Protection on missing control value

This parameter enables the protection function on missing control value telegrams. This is necessary in order to prevent unwanted and uncontrolled overheating or cooling down of the room, when the control value is missing.

Protection takes effect, as soon as no telegrams are received from the controller over a longer period of time. As soon as this extended telegram pause has occurred, it can be assumed that the corresponding controller has failed or the connection between the controller and the valve actuator has been interrupted.

Protection control value (PWM)

If the protection on missing control value is enabled, this parameter sets a protection control value. This configured PWM value will set the output, if the protection is active.

As soon as telegrams from the controller are received again, the protection control value (PWM) is overwritten by the received value. The protection does not react again, until the waiting time in the set monitoring interval is exceeded between individual telegrams.

Monitoring interval

If the protection on missing control value is enabled, this parameter sets the monitoring interval. If no further telegram is received by the device during this time, the protection function takes effect.

Lock function (with valve actuator)

With this parameter the lock function can be disabled or enabled. If this functionality is activated, the associated group objects as well as the parameter page "Actuator 1: Lock function" are displayed for further configuration. If the lock has been activated via the group object „Lock“, the received switching telegrams are not executed.

In addition to the lock object, there is also a priority object, which can be used to set a control value independently of the lock. Thus, it is possible to set an output PWM without affecting other functions.

When the lock is ended, the last received value (not priority object) is represented as PWM at the output.

Group object	Type KNX	Size	Direction
GO 15 Actuator A: Lock - Activate	1.001	1 Bit	From KNX
GO 17 Actuator A: Prior. valve actuator (PWM) - Control value	5.001	1 Byte	From KNX

12.8 Actuator A: Lock function

Polarity of object

This parameter defines, if the lock should be activated by receiving a 1 or by receiving a 0.

The following options are selectable:

- Lock active on 1
- Lock active on 0

Behavior on start

This parameter defines, which behavior the output should represent, if the lock activates.

The following options are selectable:

- No reaction
The PWM value remains as to begin of the lock function.
- Value
When the lock is activated, a defined PWM value is represented on the output.

Control value (PWM)

If a defined PWM value should be set to the output when the lock is activated, this value can be set with this parameter.

13 Binary inputs

The following settings are available for using the binary inputs.

13.1 Input B1/B2: General

Name (30 characters)

An arbitrary name can be assigned for the channel. However, this should be clear and meaningful, this makes it easier to work with the associated group objects, because the given name is displayed there as a label. If no name is assigned, the group objects are named "Input ..." with the channel number, which is also used in this manual. The 1st channel will be described below, the functioning of the other 3 channels is according to the 1st.

Function

This parameter defines the functionality of the connected contact. The following options are selectable:

- Disabled
- Switching
- Dimming
- Shutter
- Send value
- Scene
- Generic

A more detailed description of the functions can be found in the individual function descriptions.

The following options are also available for local operation of the dimmer channel:

- Toggle dimmer INTERN
- Switch on dimmer INTERN
- Switch off dimmer INTERN

A more detailed description of the functions can be found in the individual function descriptions.

Function "Switching, Dimming, Shutter, Send value, Scene or Generic"

If an input function of a channel is selected, the following parameters are displayed:

Type

The mode of operation of the contact connected to the input channel can be configured here:

- Normally open contact
- Normally closed contact

Lock function

With this parameter the lock function can be enabled. If this functionality is activated, the associated group objects as well as the parameter page "10.11 Input B1/B2: Lock function" are displayed for further configuration. If the lock has been activated via the group object, no telegrams are triggered by state changes of the connected contact.

Group object	Type KNX	Size	Direction
GO 76 Input B1/B2: Lock - Activate	1.001	1 Bit	From KNX

Function “Impulse counter“

If the impulse counter function is selected, further parameters are displayed in the general settings of the input channel. Here, the general settings of the impulse counter are made, a scaled counter and/or counter of the rate of change must also be selected.

Input signal

Here it can be selected whether DC or alternating voltage is applied to the binary input.

Count on

This parameter can be used to determine whether the value of the counter is increased at the rising or falling edge at the input

Scaled counter (e.g. [kWh])

Here, the scaled counter can be activated, the parameter page „Scaled counter“ is displayed when activated.

Rate of change (e.g. [kW], [m/s], [km/h])

The counter for a rate of change can be activated here. If activated, the „Rate of change“ parameter page is displayed.

13.2 Input B1/B2: Switching

If the switching function is selected, up to 2 binary switching telegrams can be sent via the following objects:

Group object	Type KNX	Size	Direction
GO 71 Input B1/B2: Output a – Switch	1.001	1 Bit	To KNX
GO 72 Input B1/B2: Output b – Switch*	1.001	1 Bit	To KNX

*Output b is only visible when activated by parameter.

The time for detection of a long button press can be set in the general parameters and is valid for all inputs/buttons.

User control

The parameter “User control” determines whether telegrams are sent when the input is changed (e.g. key switches) or when the button is operated short/long (e.g. button for switching/dimming).

Function of object a/b on press

Function of object a/b on short press

Function of object a/b on release

Function of object a/b on long press

It is selectable for each object a and b, which telegram is sent on press and release or on short/long button press.

The following options are available:

- No reaction
 - Switch on
 - Switch off
 - Toggle
- On toggle the last value received from the bus is evaluated if the write flag is activated on the object.

Output b

Here you can show/hide the parameters and the object for output b.

Input B1/B2: Switching – State query

The Status query function is used, for example, to monitor window contacts.

The status query mode is automatically recognized by the firmware if the following parameter settings are present:

User control: Press / Release

Function (...) on press: Switch on

Function (...) on release: Switch off

or inverted:

User control: Press / Release

Function (...) on press: Switch off

Function (...) on release: Switch on

With configured status query, the value on the object is kept up to date. The value corresponds to the current state that is read. If the lock is active, the object value corresponds to the last status before the lock or the configured value when the lock is activated.

Cyclic sending of object a/b (only for state query)

When the status query is active, cyclic sending can be configured independently for object a and b. The following options are available:

- 1 min.
- 2 min.
- 5 min.
- 10 min.
- 20 min.
- 30 min.
- 1 h.
- 6 h.
- 12 h.
- 24 h.

HINT	
	When the lock is active, cyclic sending is disabled.

13.3 Input B1/B2: Dimming

On selection of function Dimming following objects are visible:

Group object	Type KNX	Size	Direction
GO 71 Input B1/B2: Dimming on/off – Switch	1.001	1 Bit	To KNX
GO 72 Input B1/B2: Dimming relative – Brighter/Darker	3.007	4 Bit	To KNX

HINT	
	The time for detection of a long button press can be set in the general parameters and is valid for all inputs/buttons.

Dimming function

The dimming function parameter determines whether only one switching / dimming direction or 1-button control is to be used:

The choice is yours:

- On / Dim brighter
- Off / Dim darker
- Toggle direction
On toggle direction, the last value received from the bus is evaluated if the write flag is activated on the object. This applies to object 11 and object 12.
In addition, object 13 is visible. If one of the limit values is received here as the status (e.g. 0 % or 100 %), the dimming direction is adjusted accordingly.

Group object	Type KNX	Size	Direction
GO 73 Input B1/B2: Dimming absolute – State	5.001	1 Byte	From KNX

If the input detects a short button press, a switching telegram is sent via object 11. On long button press, a relative dimming is sent over the entire dimming range to object 12. When releasing after long button press, a dimming-stop telegram is sent via object 12.

The time for detection of a long button press can be set in the general parameters and is valid for all channels.

Dimming direction after switch on (only for toggle direction)

This parameter is only visible on toggle direction and determines the dimming direction of the next dimming command following an ON telegram.

This is useful in the bathroom, for example, when the light is switched on at low brightness at night and then should be dimmed brighter.

13.4 Input B1/B2: Shutter

On selection of Shutter function following objects are visible:

Group object	Type KNX	Size	Direction
GO 71 Input B1/B2: Drive start – Up/Down	1.001	1 Bit	To KNX
GO 72 Input B1/B2: Drive stop – Step/Stop	1.001	1 Bit	To KNX

HINT	
	The time for detection of a long button press can be set in the general parameters and is valid for all inputs/ buttons.

Shutter direction

The parameter “Shutter direction” determines whether only one shutter direction or 1-button control is to be used.

- Up
- Down
- Toggle
If the write flags are set, the shutter objects evaluate the last value received from the bus. This keeps the direction and state of the shutter in the button up to date. This applies to object 11 and object 12. In addition, object 13 is visible. If one of the limit values is received here as the status (e.g. 0 % or 100 %), the driving direction is adjusted accordingly.

Group object	Type KNX	Size	Direction
GO 73 Input B1/B2: Blind position – State	5.001	1 Byte	From KNX

User control

The parameter “User control” determines the sending of telegrams on short and long button press:

- KNX standard: Long / Short
This is the standard configuration for controlling a shutter.
Long actuation: Drive command via object 11
Short actuation: Stop/Step command via object 12
Very long actuation: Additional function
- KNX standard with turning time
This is the standard configuration for controlling a shutter with the extension that a stop is triggered when the shutter is released within the turning time. Thus, you can turn the slats with dead man.
Long actuation: Drive command via object 11
Release after long actuation within turning time: Stop/Step command via object 12
Release after long actuation after turning time: No reaction
Short actuation: Stop/Step command via object 12
Very long actuation: Additional function
- KNX inverted: Short/Long
This is the inverted standard configuration for controlling a shutter. This should be used when the main usage is on move commands.
Short actuation: Drive command via object 11
Long actuation: Stop/Step command via object 12
Actuation during drive: Stop/Step command via object 12
Very long actuation: Additional function
- Short / Short
This is an optimized variant for controlling a shutter, which uses only short button presses. The step command in the actuator should be disabled.
Short actuation: Drive command via object 11
Actuation during drive: Stop/Step command via object 12
Long actuation: Additional function
- Short / Short plus Long with turning time
This is an optimized variant for controlling a shutter, which mainly uses short button presses. A long button press can additionally be used to turn the slats.
The step command in the actuator should be disabled.
Short actuation: Drive command via object 11
Long actuation: Drive command via object 11
Release after long actuation within turning time: Stop/Step command via object 12
Release after long actuation after turning time: No reaction
Actuation during drive: Stop/Step command via object 12
Very long actuation: Additional function

- **Hold (Deadman switch)**
The dead man operation mode can be used for applications with short moving time, for example for skylights. The step command in the actuator should be disabled.
On actuation: Drive command via object 11
On release: Stop/Step command via object 12
- **Hold with turning time**
This operating mode is suitable for applications with mainly short moving times, with the addition that long moving times, by holding beyond the turning time, can also be easily realized. The step command in the actuator should be disabled.
On actuation: Drive command via object 11
On release within turning time: Stop/Step command via object 12
On release after turning time: No reaction
- **Hold, delayed with turning time**
This is analog to the operating mode „Hold with turning time“, with the difference that the movement is on the long button press. The step command in the actuator should be disabled.
Long actuation: Drive command via object 11
Release after long actuation within turning time: Stop/Step command via object 12
Release after long actuation after turning time: No reaction
Short actuation: Additional function
Actuation during drive: Stop/Step command via object 12

Drive time (Time window for stop) [s]

Only displayed for the user controls with “Actuation during drive: Stop/Step command”. The time window for the actuation at which a stop/step command is sent is set here.

Turning time [s]

Only displayed for the user controls with turning time. In general, by releasing within the turning time, the shutter can be stopped while continuing to move after the turning time.

HINT	
	If the button tone is activated on the „General settings“ page, the end of the turning time is indicated by a signal tone..

Additional function on short/long/very long button press

The following functions can be triggered by short/long/very long keystrokes:

- Switch on
- Switch off
- Toggle
On toggle, the last value received from the bus is evaluated if the write flag is activated on the object.

Group object	Type KNX	Size	Direction
GO 74 Input B1/B2: Additional function – Switch	1.001	1 Bit	To KNX

- Dim brighter
- Dim darker

Group object	Type KNX	Size	Direction
GO 74 Input B1/B2: Additional function - Dimming relative	3.007	4 Bit	To KNX

- Drive up
- Drive down

Group object	Type KNX	Size	Direction
GO 74 Input B1/B2: Additional function – Up/Down	1.008	1 Bit	To KNX

- Step up / Stop
- Step down / Stop

Group object	Type KNX	Size	Direction
GO 74 Input B1/B2: Additional function – Step/Stop	1.007	1 Bit	To KNX

- Send value
With this function, a byte value can be sent. A parameter for selecting the value is displayed

Group object	Type KNX	Size	Direction
GO 74 Input B1/B2: Additional function – Send value	5.001	1 Byte	To KNX

- Call scene
With this function, a scene can be sent. A parameter for selecting the scene is displayed

Group object	Type KNX	Size	Direction
GO 74 Input B1/B2: Additional function – Call scene	18.001	1 Byte	To KNX

- Save scene
With this function, a scene can be saved. A parameter for selecting the scene is displayed.

Group object	Type KNX	Size	Direction
GO 74 Input B1/B2: Additional function – Save scene	18.001	1 Byte	To KNX

Very long button press after [s]

This parameter is visible only when using the very long actuation, it sets the time to detect a very long button press.

13.5 Input B1/B2: Send value

If function Send value is selected, the following telegrams can be sent at button press:

- 1 byte - Percent value

Group object	Type KNX	Size	Direction
GO 71 Input B1/B2: Send percent value (1 byte) – Set value	5.001	1 Byte	To KNX

- 1 byte - Integer value

Group object	Type KNX	Size	Direction
GO 71 Input B1/B2: Send integer value (1 byte) – Set value	5.010	1 Byte	To KNX

- 2 byte - integer value

Group object	Type KNX	Size	Direction
GO 71 Input B1/B2: Send integer value (2 byte) – Set value	7.001	2 Byte	To KNX

- 2 byte - Float value

Group object	Type KNX	Size	Direction
GO 71 Input B1/B2: Send float value (2 byte) – Set value	9.001	2 Byte	To KNX

- 3 byte - RGB value

Group object	Type KNX	Size	Direction
GO 71 Input B1/B2: Send RGB color value (3 byte) – Set value	232.600	3 Byte	To KNX

- 14 byte - ASCII string

Group object	Type KNX	Size	Direction
GO 71 Input B1/B2: Send ASCII string (14 byte) – Set value	16.000	14 Byte	To KNX

- Shutter

Group object	Type KNX	Size	Direction
GO 71 Input B1/B2: Send blind position – Set position	5.001	1 Byte	To KNX
GO 72 Input B1/B2: Send slat position – Set position	5.001	1 Byte	To KNX

HINT

 If the shutter is selected as the value to be sent, height is sent on button press, lamella is sent on releasing the button, if the respective value is used.

A field for entering the values to be sent is displayed, as well as the objects appropriate to the selected type.

13.6 Input B1/B2: Scene

On selection of Scene function the following object is visible:

Group object	Type KNX	Size	Direction
On selection of Scene function the following object is visible:	18.001	1 Byte	To KNX

HINT



The time for detection of a long button press can be set in the general parameters and is valid for all inputs/buttons.

Scene position 1 - 8

For each position, scene 1 – 64 can be activated.

If only one scene position is activated, it is sent on short button press.

If several scene positions are used, the activated positions are switched through with each short button press. The behavior for selecting and sending the scene positions can be determined by the following parameter.

Reset scene position

The following options are available:

- Never
Starting with the first scene position, the next position of the list is sent with each short button press, after the last scene position has been sent, the list starts again from the beginning
- After execution
This selection enables the parameter **Time until execution**.
Beginning with the first scene position, each short button press switches the position by one position within the execution delay, at the end of the execution delay, the current scene position is sent.
- 5 s. ... 10 min.
On each button press the configured delay time is started.
Starting with the first scene position, the next position of the list is sent with each short button press, after the last scene position has been sent, the list starts again from the beginning.
After the delay time has expired, the list starts again at the first scene position on the next short button press.

HINT



When the button lock is used, the scene position is always reset when unlocking.

Condition on long button press

Condition on very long button press

It is also possible to select how a long and very long button press should be handled:

- No reaction
- Reset position
This function is used to override the behavior as set in the parameter **Reset scene position**.
- Call scene
The scene configured in the appearing parameter is sent.
- Save last scene
A telegram for “save scene” with the last sent scene is triggered.
- Additional function

Additional functions

The following functions can be triggered by a long or very long button press:

- Switch on
 - Switch off
 - Toggle
- On toggle, the last value received from the bus is evaluated if the write flag is activated on the object.

Group object	Type KNX	Size	Direction
GO 75 Input B1/B2: Additional function – Switch	1.001	1 Bit	To KNX

- Dim brighter
- Dim darker

Group object	Type KNX	Size	Direction
GO 75 Input B1/B2: Additional function – Dimming relative	3.007	4 Bit	To KNX

- Drive up
- Drive down

Group object	Type KNX	Size	Direction
GO 75 Input B1/B2: Additional function – Up/Down	1.008	1 Bit	To KNX

- Step up / Stop
- Step down /Stop

Group object	Type KNX	Size	Direction
GO 75 Input B1/B2: Additional function – Step/Stop	1.007	1 Bit	To KNX

- Send value
- With this function, a byte value can be sent. A parameter for selecting the value is displayed.

Group object	Type KNX	Size	Direction
GO 75 Input B1/B2: Additional function – Send value	5.001	1 Byte	To KNX

Very long button press after [s]

This parameter is visible only when using the very long actuation, he sets the time to detect a very long button press.

13.7 Input B1/B2: Generic

With this button function, a separate object is available for each event at the input/pushbutton in order to set the function of the input/pushbutton individually.

These events at the input/button and their associated objects are:

- Button - Pressed

Group object	Type KNX	Size	Direction
GO 71 Input B1/B2: Pressed – ...	Depending on function		To KNX

- Button - Released

Group object	Type KNX	Size	Direction
GO 72 Input B1/B2: Released – ...	Depending on function		To KNX

- Button – Pressed short

Group object	Type KNX	Size	Direction
GO 73 Input B1/B2: Pressed short – ...	Depending on function		To KNX

- Button – Pressed long

Group object	Type KNX	Size	Direction
GO 74 Input B1/B2: Pressed long – ...	Depending on function		To KNX

- Button – Pressed very long

Group object	Type KNX	Size	Direction
GO 75 Input B1/B2: Pressed very long – ...	Depending on function		To KNX

Each event can be assigned the following functions:

- Switch on
 - Switch off
 - Toggle
- On toggle the last value received from the bus is evaluated if the write flag is activated on the object.

Group object	Type KNX	Size	Direction
GO ... Input B1/B2: ... – Switch	1.001	1 Bit	To KNX

- Dim brighter (no Stop)
- Dim darker (no Stop)
- Dim Stop

Group object	Type KNX	Size	Direction
GO ... Input B1/B2: ... – Dimming relative	3.007	4 Bit	To KNX

- Drive up
- Drive down

Group object	Type KNX	Size	Direction
GO ... Input B1/B2: ... – Up/Down	1.008	1 Bit	To KNX

- Step up / Stop
- Step down / Stop

Group object	Type KNX	Size	Direction
GO ... Input B1/B2: ... – Step/Stop	1.007	1 Bit	To KNX

- Send value
With this function, a byte value can be sent. A parameter for selecting the value is displayed.

Group object	Type KNX	Size	Direction
GO ... Input B1/B2: ... – Send value	5.001	1 Byte	To KNX

- Call Scene
With this function a scene can be sent, a parameter for selecting the scene is displayed.

Group object	Type KNX	Size	Direction
GO ... Taster A0: ... – Call scene	18.001	1 Byte	To KNX

- Save scene
With this function a scene can be saved, a parameter for selecting the scene is displayed.

Group object	Type KNX	Size	Direction
GO ... Taster A0: ... – Save scene	18.001	1 Byte	To KNX

The time for detection of a long button press can be set in the general parameters and is valid for all inputs/buttons.

Very long button press after [s]

This parameter is visible only when using the very long actuation, he sets the time to detect a very long button press.

Long triggering (with very long keystroke)

This parameter is only visible when the long and very long actuation is used simultaneously.

If this parameter is activated, both events are always triggered after a very long actuation; if it is deactivated, the duration of the activation is evaluated: if it lies between the time of long and very long actuation, only the function for long actuation is triggered. If the time for very long actuation is exceeded, only the function for very long actuation is triggered.

13.8 Input B1/B2: Scaled counter

This counter can be used to count values on input impulses, where an integer value or a floating-point value can be selected as a counter variable. With this function, e.g. Electrical energy can be counted directly and sent to the bus via an object.

Scaling factor (Value per pulse)

Here, a floating-point value is to be entered. It determines the value by which the counter value is increased per pulse.

Datapoint type

The datapoint type of output object of the counter variable can be selected here:

- Integer (32 Bit) – DPT 13

Group object	Type KNX	Size	Direction
GO 71 Input B1/B2: Counter – Value	13.013	4 Byte	To KNX

- Float (16 Bit) – DPT 9

Group object	Type KNX	Size	Direction
GO 71 Input B1/B2: Counter – Value	9.024	2 Byte	To KNX

- Float (32 Bit) – DPT 14

Group object	Type KNX	Size	Direction
GO 71 Input B1/B2: Counter – Value	14.056	4 Byte	To KNX

Send condition

This parameter can be used to determine how the current counter value is to be sent:

- On read
No independent sending of the counter value by the device. To read the counter value, the read-flag of the group object has to be set.
- On change
An additional parameter is displayed to select the minimal delta from the last sent value for sending a new counter value.
- Cyclically
An additional parameter is displayed to configure the sending frequency of the counter variable.
- On change and cyclically
Both sending conditions are active.

If the counter is locked by the object, also cyclic sending is stopped.

Monitoring limit value

When limit monitoring is activated, the following object is displayed:

Group object	Type KNX	Size	Direction
GO 72 Input B1/B2: Counter threshold – State	1.002	1 Bit	To KNX

When limit monitoring is activated, the following parameters are displayed:

Limit value

Here you can edit the checked limit value. The datapoint type is the same as the counter value.

Behavior on reaching limit value (object)

Here it is possible to determine whether a 0 or a 1 is sent via the object "Counter threshold – State" when the limit value is reached.

Behavior on reaching limit value (counter)

In addition to the limit value itself, it is possible to determine the behavior of the counter when the limit value is reached:

- Counter continue
Counter value continues increasing on ever pulse
- Counter reset and continue
Counter value is reset to 0 and continues increasing on ever pulse
- Counter stop
Counter value stays on limit value and must be reset by object

Send on device restart

It can be determined with this parameter whether the counter value should be sent when the device is restarted.

Reset via object

If this function is activated, the following object appears:

Group object	Type KNX	Size	Direction
GO 73 Input B1/B2: Reset – Trigger	1.017	1 Bit	From KNX

When a telegram is received via this object, the current count values are reset to 0.

Reset after ETS download

If this parameter is activated, the counter values are reset to 0 after device reset (e.g. after ETS download), otherwise they are retained.

Lock function

The lock function can be activated or deactivated here. If this functionality is activated, the following group object appears, as well as the parameter page „Input B1/B2: Lock function“ for detailed configuration.

Group object	Type KNX	Size	Direction
GO 76 Input B1/B2: Lock – Activate	1.001	1 Bit	From KNX

If the lock has been activated via the group object, state changes at the input do not cause an increase of the counter variable.

13.9 Input B1/B2: Rate of change

This counter is used to connect devices to the bus where the rate of change within a time interval is crucial, e.g. an anemometer.

Scaling factor (Value per delta in base time span)

A floating-point value is to be entered here. It determines the value by which the counter value is increased on every pulse

Time base

Here the time base of the rate of change can be specified:

- Pulses per second (e.g. [m/s], [km/h])
Value from parameter Scaling factor is multiplied by 1
- Pulses per hour (e.g. [kW])
Value from parameter Scaling factor is multiplied by 3600

Measurement time span

The measurement time span determines how quickly the counter can react to changes. Therefore, a short sample rate should be selected for fast processes (e.g. anemometer).

The rate of change is calculated using the 3 parameters mentioned above:

The device saves several meter readings per measurement interval, scales it with the scaling factor * time base and divides it by the measuring interval.

Datapoint type

The datapoint type of output object of the counter variable can be selected here:

- Floating point (16 Bit) - DPT 9

Group object	Type KNX	Size	Direction
GO 74 Input B1/B2: Rate of change – Value	9.024	2 Byte	To KNX

- Floating point (32 bit) - DPT 14

Group object	Type KNX	Size	Direction
GO 74 Input B1/B2: Rate of change – Value	14.056	4 Byte	To KNX

Send condition

This parameter can be used to determine how the current counter value is to be sent:

- On read
No independent sending of the counter value by the device. To read the counter value, the read-flag of the group object has to be set.
- On change
An additional parameter is displayed to select the minimal delta from the last sent value for sending a new counter value.
- Cyclically
An additional parameter is displayed to configure the sending frequency of the counter variable.
- On change and cyclically
Both sending conditions are active.

Monitoring limit value

When limit monitoring is activated, the following object is displayed:

Group object	Type KNX	Size	Direction
GO 75 Input B1/B2: Rate threshold – State	1.002	1 Bit	To KNX

When limit monitoring is activated, the following parameters are displayed:

Limit value

Here you can edit the checked limit value. The datapoint type is the same as rate of change value.

Behavior on exceeding limit value

In addition to the limit value itself, it is possible to determine whether the counter should transmit 0 or 1 via the object if the limit value is exceeded.

Behavior on going below limit value

Here it is possible to determine whether the counter should transmit 0 or 1 via the object if the counter variable goes under limit value

Example: Electricity meter with SO interface

From the data sheet of the electricity meter it can be seen that the device delivers 500 pulses per kWh. A device with constant power of 1kW is connected to this current meter for one hour.

The scaled counter measures the energy consumed:

Scaling factor (Output in kWh): 1 / 500 = 0.002

The counter for the rate of change measures the current power:

Scaling factor (Output in kW): 1/500 = 0.002

*Scaling factor (Output in W): 1/500 * 1000 = 2*

Time base: Pulses per hour

Measurement time span: 300 s

Example: Anemometer

From the data sheet of the electricity meter it can be seen that the device delivers 4 pulses/s at a wind speed of 1 m/s. The counter for the rate of change measures the wind speed:

Scaling factor (Output in m/s): $1/4 = 0.25$

Scaling factor (Output in km/h): $1/4 * 3.6 = 0.9$

Time base: Pulses per second

Measurement time span: 10 s

13.10 Input B1/B2: Lock function

Lock function "Switching"

Polarity of object

This parameter defines, if the lock should be activated by receiving a 1 or by receiving a 0. The respective opposite telegram deactivates the lock again.

Behavior of object a/b on start

The telegram can be configured here, which is sent on the according object when the lock is activated.

Behavior of object a/b at end

The telegram can be configured here, which is sent on the according object when the lock is deactivated.

Lock function "Dimming, Shutter, Send value, Color, Scene"

Polarity of object

This parameter defines, if the lock should be activated by receiving a 1 or by receiving a 0. The respective opposite telegram deactivates the lock again.

Behavior on start

The telegram can be configured here, which is sent on the according object when the lock is activated.

Behavior at end

The telegram can be configured here, which is sent on the according object when the lock is deactivated.

Lock function "Generic" – Polarity of object

This parameter defines, if the lock should be activated by receiving a 1 or by receiving a 0. The respective opposite telegram deactivates the lock again.

Lock function "Scaled counter"

Only with the lock function activated and with the 'Pulse counter' function.

Polarity of object

This parameter can be used to determine how the lock is to be activated, either by receiving a 1 or a 0. The corresponding telegram disables the lock again.

Behavior on start of lock

With this parameter the behavior of the counter can be configured when the lock is activated:

- Counter stop
- Counter stop and reset

Behavior on end of lock

With this parameter the behavior of the counter can be configured when the lock is deactivated:

- Counter continue
- Counter reset and continue

14 Logic / Timing

Function 1 - 16

These parameters contain the functions timer and logic, whereby all 16 functions are identical.

The following options are available:

- Disabled
No parameters and group objects for timer and logic.
- Timer
Parameters and group objects for timer are available.
- Logic
Parameters and group objects for logic are available.

HINT



The functions for timer and logic can be linked to one another by means of the associated group objects. This also allows to create complex structures. For this purpose, the output of a function is set to the same group address as the input of the next function.

14.1 Function 1 - 16 : Timer

Function name (10 characters)

The function name can be chosen freely.

The name is visible in the group object entry in the ETS software. This makes it easier to work with the associated group objects, because the given name is displayed there as a label.

Timer type

Here the type of the timer can be set:

- Switch-on delay
The ON telegram (1) received on the input is delayed on the output.
Input: --1-----0-----
Output: --|T-1-----0-----

Group object	Type KNX	Size	Direction
Timer – Switch-on delayed – Input	1.002	1 Bit	From KNX
Timer – Switch-on delayed – Output	1.002	1 Bit	To KNX

- Switch-off delay
The OFF telegram (0) received on the input is delayed on the output.
Input: --1-----0-----
Output: --1-----|T-0-

Group object	Type KNX	Size	Direction
Timer – Switch-off delayed – Input	1.002	1 Bit	From KNX
Timer – Switch-off delayed – Output	1.002	1 Bit	To KNX

- Switch-on and -off delay
The ON/OFF telegram (1/0) received on the input is delayed on the output.
Input: --1-----0-----
Output: --|T-1-----|T-0-

Group object	Type KNX	Size	Direction
Timer – Switch-on/off delayed – Input	1.002	1 Bit	From KNX
Timer – Switch-on/off delayed – Output	1.002	1 Bit	To KNX

- Impulse (staircase)
The ON telegram (1) received on the input is sent on the output. After a delay the output sends the OFF telegram (0).
Input: --1-----0-----
Output: --1-T-0-----

Group object	Type KNX	Size	Direction
Timer – Impulse (staircase) – Input	1.002	1 Bit	From KNX
Timer – Impulse (staircase) – Output	1.002	1 Bit	To KNX

HINT

Each timer can be stopped by sending the opposite value to its input group object. For example: An already started switch-on timer can be stopped by sending OFF (0) to its input group object.

Delay [s]

This parameter defines the delay when sending at the output.

Output

Via this parameter the sent value on the output can be inverted:

- Not inverted
- Inverted

14.2 Function 1 - 16: Logic

Function name (10 characters)

The function name can be chosen freely.

The name is visible in the group object entry in the ETS software. This makes it easier to work with the associated group objects, because the given name is displayed there as a label.

Gate type

This parameter defines the type of the logic gate:

- And gate
The output is triggered ON (1), if both inputs are switched ON (1).
- OR gate
The output is triggered ON (1), if one or both inputs are switched ON (1).
- XOR gate
The output is triggered ON (1), if the two inputs are not equal.
- NAND gate
The output is triggered ON (1), if one or both inputs are switched OFF (0).
- NOR gate
The output is triggered ON (1), if both inputs are switched OFF (0).
- XNOR gate
The output is triggered ON (1), if both inputs are equal.

Group object	Type KNX	Size	Direction
Logic – Gate input A – Input	1.002	1 Bit	From KNX
Logic – Gate input B – Input	1.002	1 Bit	From KNX
Logic – Gate output – Output	1.002	1 Bit	To KNX

HINT

The output transmits when a telegram is received on one of the inputs. A precondition for this is that both inputs are valid (have received at least one telegram). The output sends a 1 if the respective condition is fulfilled, otherwise a 0.

- INVERTER
Input ON (1) is converted into output OFF (0). Input OFF (0) is converted into output ON (1).

Group object	Type KNX	Size	Direction
Logic – Gate input – Input	1.002	1 Bit	From KNX
Logic – Gate output – Output	1.002	1 Bit	To KNX

HINT

The output transmits when a telegram is received on the input.

WARNING

- The device must be mounted and commissioned by an authorized electrician.
- The prevailing safety rules must be heeded.
- The device must not be opened.
- For planning and construction of electric installations, the relevant guidelines, regulations and standards of the respective country are to be considered.
- The device is a permanently connected equipment: A readily accessible disconnect device shall be incorporated external to the equipment.
- The installation requires a 16 A fuse for external overcurrent protection.
- The power rating is indicated on the side of the product.

15 Service / Support

15.1 Manufacturer's warranty

B.E.G. Brück Electronic GmbH grants a warranty in accordance with the warranty conditions, which you can download from the website at <https://www.beg-luxomat.com/service/downloads/>.

15.2 Contact details

Service hotline:

+49 (0)2266 90121-0

Monday to Thursday 8.00 to 16.00 (UTC+1)

Friday 8.00 to 15.00 (UTC+1)

E-mail:

support@beg.de

Return address for repairs:

Please contact your B.E.G. branch or representative.

You can find the contact details at <https://www.beg-luxomat.com/en-in/service/service-points/>.

Or contact us directly at

B.E.G. Brück Electronic GmbH

Gerberstrasse 33

51789 Lindlar

GERMANY



B.E.G. Brück Electronic GmbH
Gerberstraße 33
51789 Lindlar

T +49 (0) 2266 90121-0

support@beg.de
beg-luxomat.com