

1. Mounting preparations

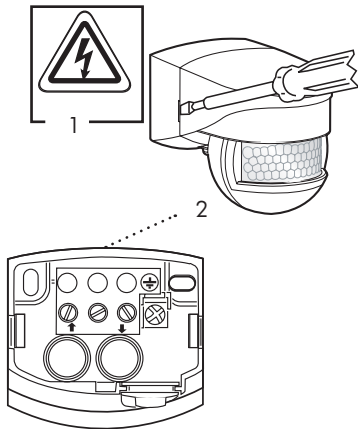

1) **Caution: have all work involving the 230V mains supply carried out by a qualified electrician! Before starting disconnect the mains! Please be aware, that the LUXOMAT® LC-Mini 120/180 is not suitable as an intrusion detector, since it is not equipped with a tamper contact.**

2) Socket base corner mounting

Important: The LUXOMAT® LC-Mini 120/180 has to be mounted in such a way, that the adjusting elements / rotary regulators are always pointed downward.

2. Mounting types

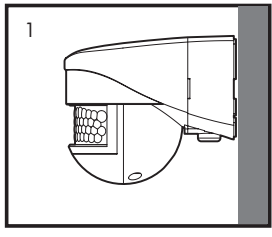

1) Wall mounting

4. Inserting of the connection cable

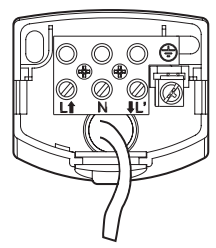

1) Connection cable from top down
2) Terminal markings

6. Connection

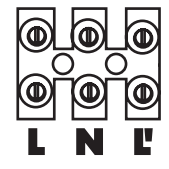

3. Plug-in socket

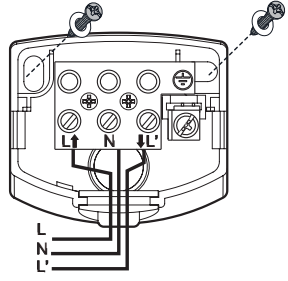

Mount the plug-in socket with two screws and the enclosed seal rings on a firm base. (Pay attention to inserting of the connection cable, see point 4)

5. Sensor head optics

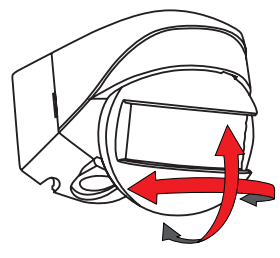

By swinging the sensor head horizontally (ca. ±45°) and vertically (ca. ±15°) the detection area can be changed.

7. Exclude sources of interference

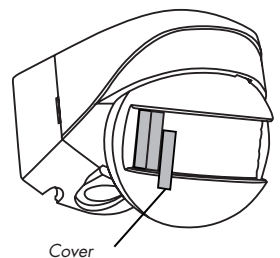

If necessary, the lens segment(s) corresponds to unwanted detection zones may be masked with the enclosed covers to reduce the field of vision.

8. Putting into operation / Settings

Self test cycle

After mounting and connecting the 230 VAC supply voltage, the detector pass a self-test. Afterwards the settings can be made manually.

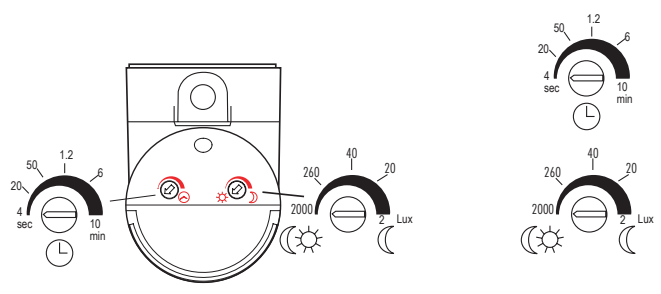

Follow-up time
4 sec. ... 10 min.

Lux value
Night operation...Dusk...Day operation
(Day operation: light sensor inactive, switching at any brightness value)

9. Range of Coverage

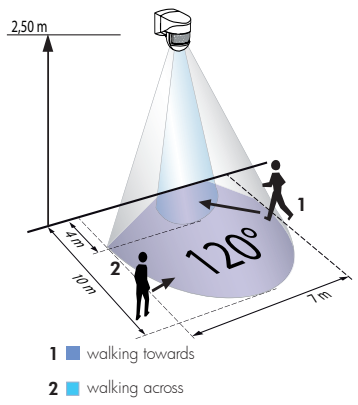

1 walking towards
2 walking across

10. Mounting place

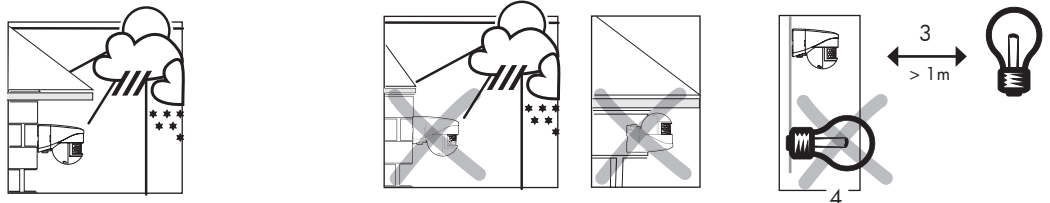

1) If possible mount unit on a safe place (wall or ceiling mount)
2) Influence of weather reduces the lifetime of the unit. Please take care to mount correctly.
3) Minimum distance to switched lighting, frontally or laterally to device: 1 m
4) Never mount the connected lights below the motion detector!

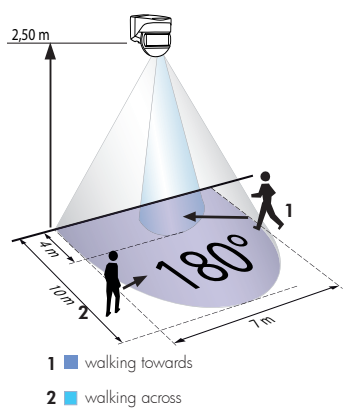

1 walking towards
2 walking across

11. Wiring diagrams

Standard mode with 1-channel motion detector

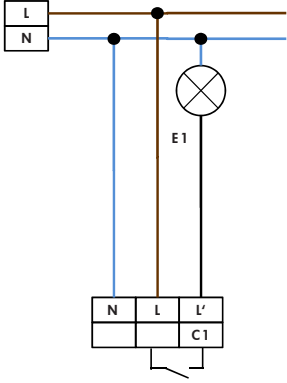

Standard mode with 1-channel motion detector with permanent light function

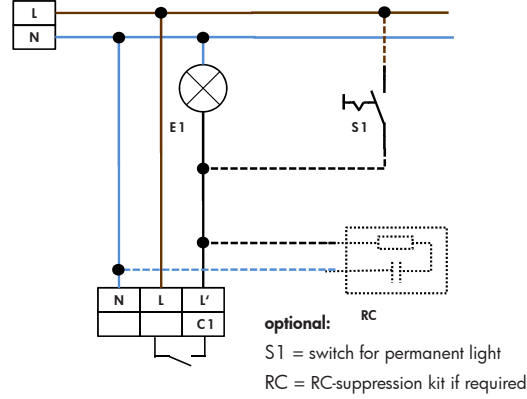

Standard mode with 1-channel motion detector with NC pushbutton

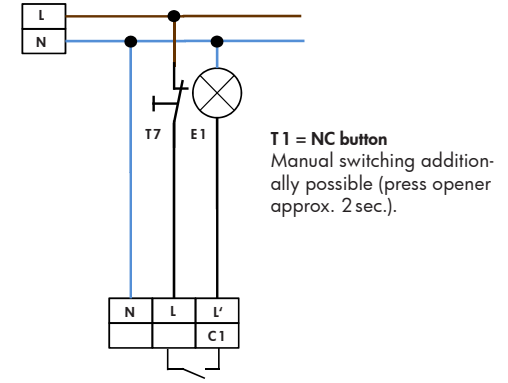

Parallel connection with 1-channel motion detectors

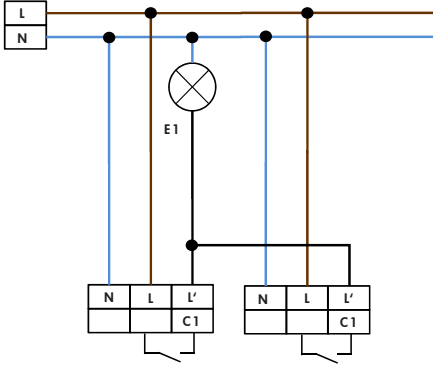

Standard mode with 1-channel motion detector (e.g. stairs)

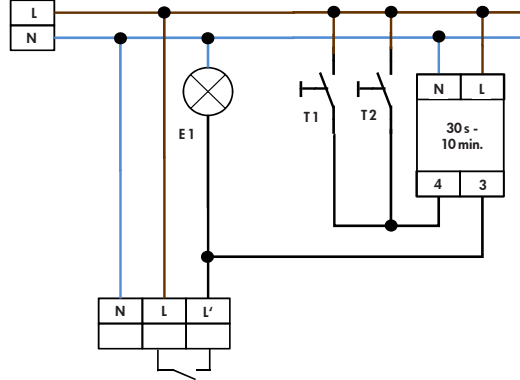

12. Dimensions (mm)

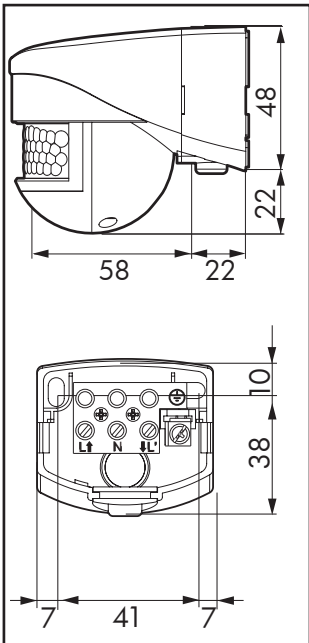

13. Trouble Shooting-Practical hints

1. Lamp does not light up

Cause - Action

- Lamp is defective
 - Replace light bulb.
- No mains connection
 - Check mains fuse.
- Switching threshold of the twilight switch is not correct
 - Accordingly adjust sensitivity of twilight switch via the setting dial.

Detection area not set correctly

Set detection area correctly.

Unit mounted too high

- Mount at recommended height (2.50 m)
- PIR detector lens obstructed by dirt or other objects
 - Clean lens or remove objects

2. Delayed lamp activation

Mounted too high

- Mount at height stated in specification (2.5 m)

Only direct in-line approach of detector is possible

- Mount detector in such a way that a sideways approach is also detected.

3. Lamp stays on continuously

Continuous thermal movement within detection area

- Remove the heat source out of the detection area.

Check the correct functioning of the detector in fully covering the lens (lights should go out after a certain time-delay).

Motion detector is switched parallel to a switch that enables direct manual switching on

- Mind the correct connection of the switch.

4. Light source remains on for long periods when no persons are present

Permanent influence from heat sources within detection area (trees, shrubs when blown by the wind, presence of animals like cats and dogs in the detection area)

- Reduce detection area of the detector in turning the detector head downward or cover parts using the enclosed covers.

Direct sunlight radiation into detector lens

- Shelter lens from direct sunlight.

Detector mounted above extractor fan

- Change mounting place of the detector.

5. Limitation of range (not up to the minimum specification)

Mounting height is not optimal

- Accordingly change mounting height (2.50 m). Persons only move directly towards the detector

- Mount detector in such a way that a sideways approach is also detected.

Steep terrains

- Adjust spherical head accordingly.

6. No reaction to vehicles

Vehicle not warmed up

Vehicle is well insulated (by silencing equipment)

14. Technical data

Power supply: 230 V- ±10 %

Detection area: LC-Mini 120
120°
LC-Mini 180
180°

Range of coverage in m:
max. 10m when walking across (tangential)

Degree of protection/class:
IP 44 / II / C E

Dimension: L 80 x B 55 x H 70 mm

Ambiente temperature: -25°C to +50°C

Package:
Housing UV- and shock-resistant Polycarbonate

Chanel 1 for light control

Contact load: 1000 W, $\cos\phi = 1$

Time-settings: 4 s - 10 min.

Brightness value: 2 - 2000 Lux

CE Declaration of Conformity:

The product complies with the low voltage recommendation 2006/95/EC/ and the EMV recommendation 2004/108/EC.

15. Article / Part nr. / Accessory

Typ	Colour	Part nr.
LC-Mini 120	white	91051
LC-Mini 120	black	91071
LC-Mini 180	white	91052
LC-Mini 180	black	91072

Accessory:
RC-Suppressor

10880